

We strongly believe that people
prefer handmade products.

NEW TERRACOTTA
— PORTUGUESE HANDMADE —

This document is intended to provide a user-friendly and informative guide for the best practice selection, preservative treatment, design and installation of New Terracotta tiles to ensure product fit for purpose and performance over a range of applications, hazard exposures and design lives. The target users would primarily be architects, designers, builders, engineers, specifiers and other users of New Terracotta tiles.

INDEX

WE ARE NEW TERRACOTTA | 2

GLAZED TILES | 7

FORMAT GUIDE

- 9 Field Tiles
- 10 Trims
- 11 New Modern
- 12 Portuguese Heritage
- 13 Layouts
- 14 Tiles per square meter

GLAZE COLOURS

- 17 Glaze References
- 23 Glaze Specifications

HAND PAINTED | 28

INSIDE THE ATELIER | 32

PURE LUX | 38

TECHNICAL GUIDE

- 43 Physical & Chemical Characteristics
- 44 Installation & Maintenance Guidelines

NATURAL COTTO | 49

FORMAT GUIDE

- 51 Field Tiles & Special Tiles
- 52 Tiles per square meter

CLAY COLOURS

- 55 Clay Colours & Shade Variation Grading

TECHNICAL GUIDE

- 57 Physical & Chemical Characteristics
- 58 Installation & Maintenance Guidelines

COMMERCIAL SUPPORT

- 63 Frequently Asked Questions
- 67 Terms & Conditions

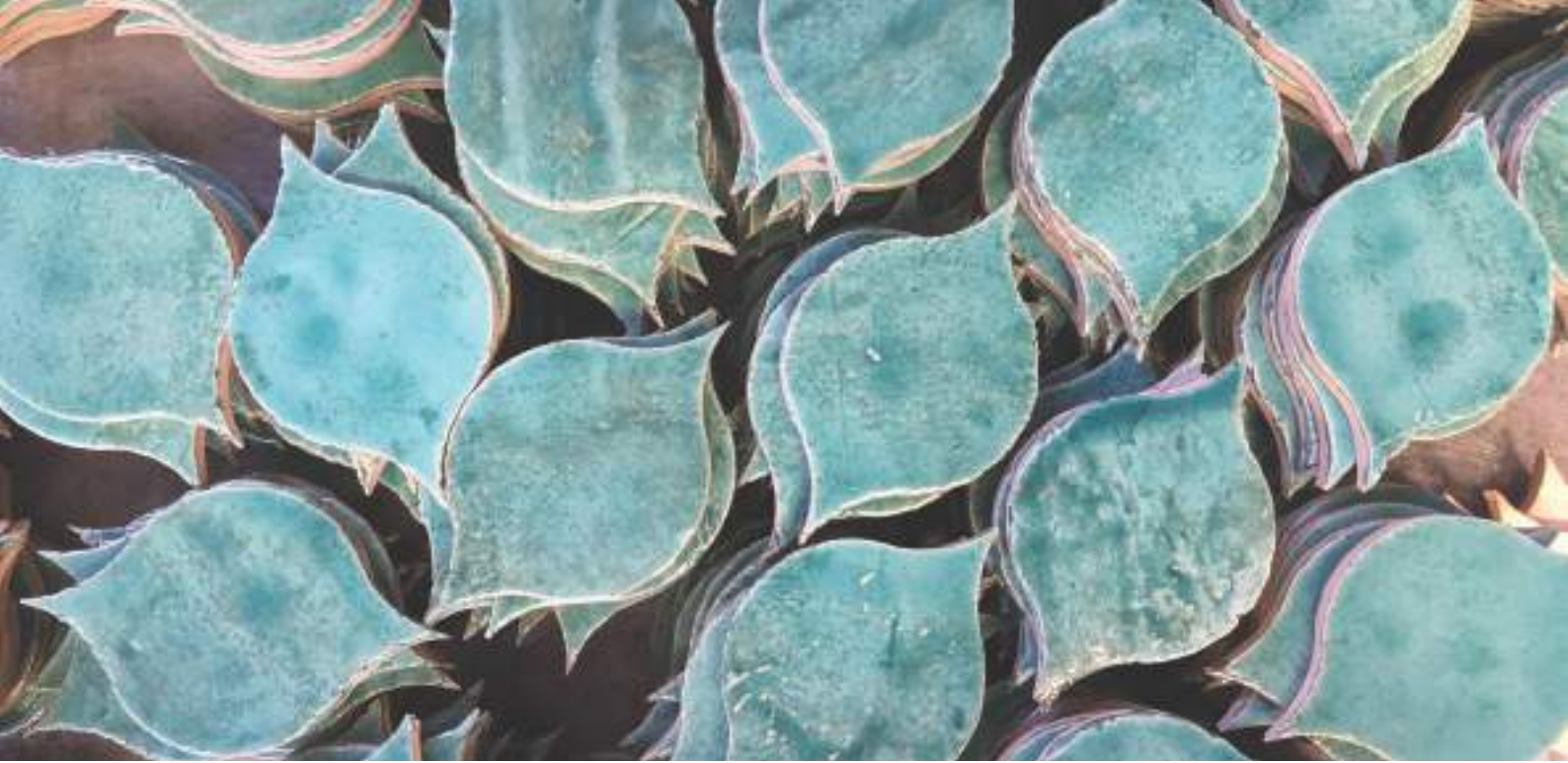

Handmade Glazed Tiles.

We are NEW TERRACOTTA

New Terracotta is a profoundly Portuguese handmade ceramic project. The premise is simple: to merge the ancient techniques with contemporary aesthetics, offering a new dimension of the tile.



Personality

Our over 142 dazzling glazes, produced by artisans using techniques passed down from generations.

Eclectic

Our unique blending of colours, shapes, textures and designs that makes up our collections.

Savoir Faire

Our ability to glaze “anything” ceramic, from tiles to objets d’art.



Handmade Natural Cotto.

For us it doesn't really make sense to talk about trends. We see our tiles as exquisite, daring, fun and exclusive.

Our Values

At New Terracotta we stand for impeccable craftsmanship and timeless design.



Be Simple.

We curate Naturalism. We value the simplicity in our tiles, sometimes we even reach out for imperfection.

Honour Origins.

We curate History. We are all about preserving artisanal legacy, as we are heirs of a rich past based on ceramic tradition.

Make Extraordinary.

We curate Quality. We pride ourselves on our attention to detail and going the extra mile to ensure that our tiles are truly unique.

We are makers of handmade tiles in a human-scale factory, neither too big nor too small.



New Terracotta was established in 2014 and is based in Central Portugal.

**Our people are what
set us apart.**



New Terracotta production team, July 2019.

At New Terracotta we are devoted to making every single tile we produce a truly incredible experience.

Making great sustainable products

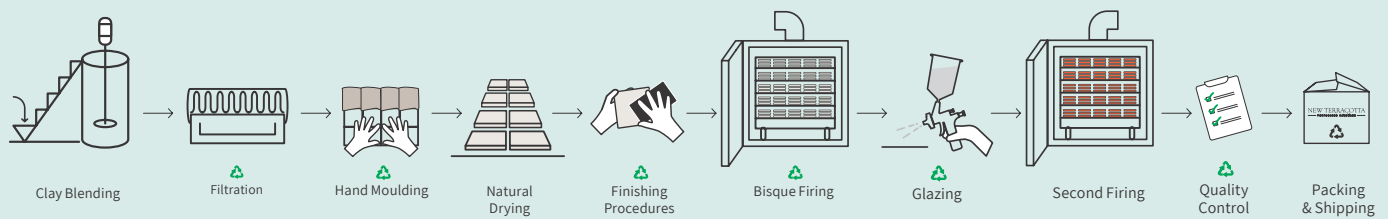

♻️ 100% glaze line water + heat + bisque + tiles + cardboxes + post-production waste.

We produce clay materials that are eco-friendly. We work hard to reduce our impact on the environment. We reclaim our own liquid waste glaze and our scrap clay and put it back into our clay body. Heat captured from our kilns is used to dry our tiles prior to firing.



WE WILL CONTINUE TO MAKE PRODUCTS THAT CAN LAST A LIFETIME. IT MAKES SENSE FOR THE CLIENT AND IT MAKES SENSE FOR THE ENVIRONMENT.



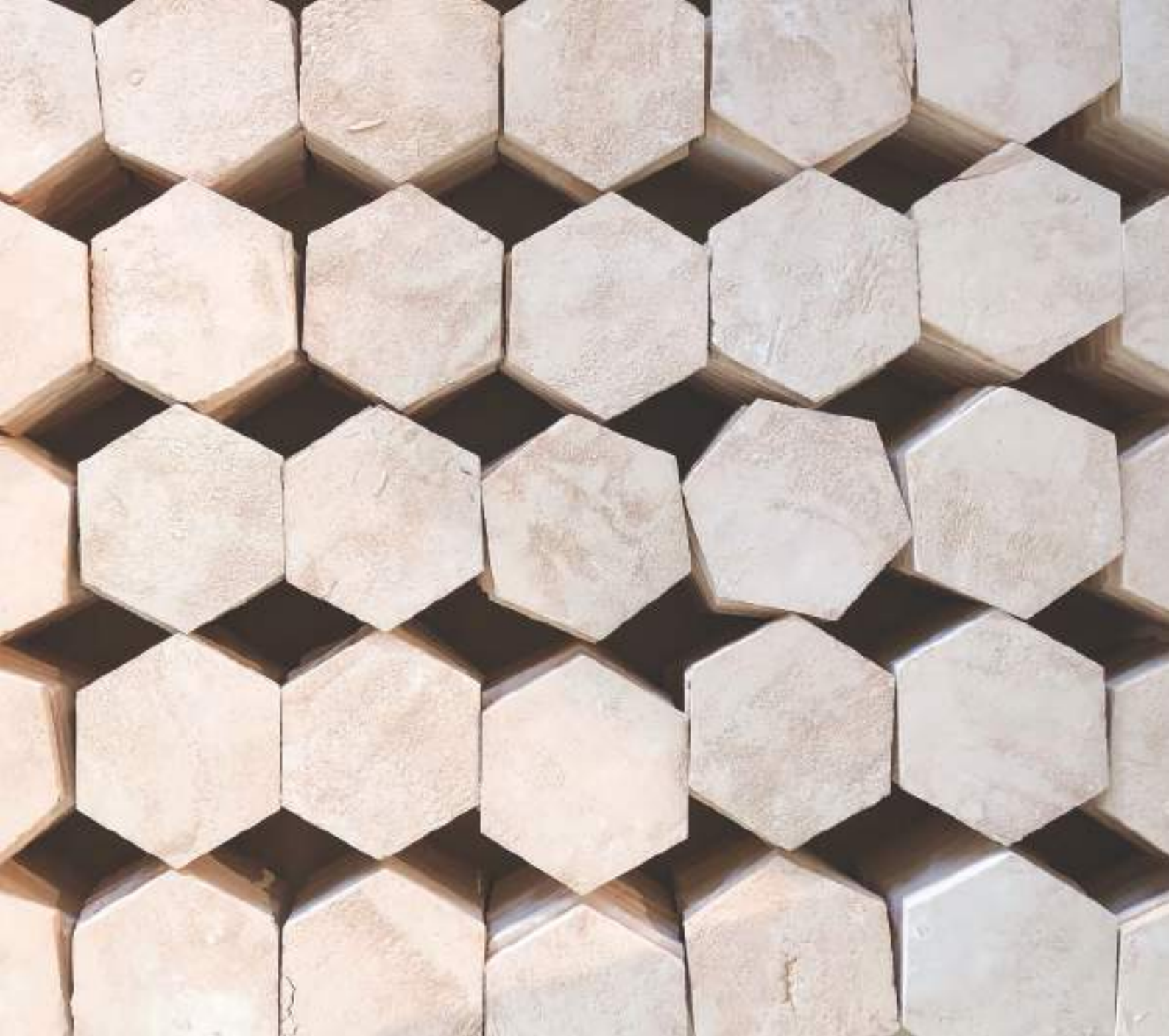

GLAZED TILES

Made from natural clays, New Terracotta hand moulded and glazed tiles manufactured using a double-firing process, are known for its variation in size, shape, colour and texture.

Our tiles are characterised by countless hues, unique nuances and particular shading details. No two pieces are exactly alike in both design and dimension and, quite often, not perfectly flat.

The irregular edges, the corrugated surface and the small imperfections are the character which makes each piece unique.

90 Formats | 142 Colours | 10 Glaze Finishes

FORMATS

**90 sizes and shapes designed to cater
any aesthetic, scale and function.**

The novelty, purity and originality of these formats foster a new psychology of perception in architecture and interior design.

FIELD TILES



SQUARE
14 x 14 x 1



SQUARE
11 x 11 x 1



SQUARE
10 x 10 x 1



SQUARE
7 x 7 x 1



RECTANGLE
16 x 13 x 1,2



RECTANGLE
15 x 10 x 1



RECTANGLE
11 x 8 x 1



HALF SQUARE
14 x 7 x 1



HALF SQUARE
11 x 5,5 x 1



HALF SQUARE
10 x 5 x 1



SQUARE
5 x 5 x 1



LONG
30 x 10 x 1,2



LONG
20 x 8 x 1,2

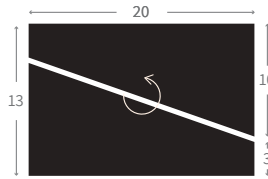

DUAL
20 x 13 x 1,2

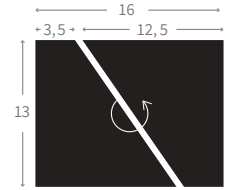

DUAL
16 x 13 x 1,2



LONG
30 x 7 x 1,2



LONG
20 x 4 x 1,2



LONG
22 x 5 x 1,2



TRIA 90° M
24 x 12 x 1,2



TRIA 90° S
12 x 12 x 1

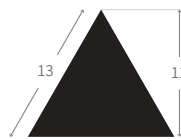

TRIA M
side 13 x 1



TRIA S
side 10 x 1

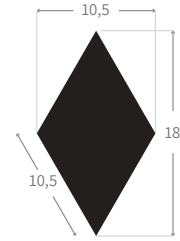

LOSA M
side 10,5 x 1

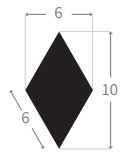

LOSA S
side 6 x 1

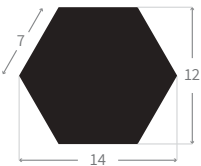

HEXA M
side 7 x 1

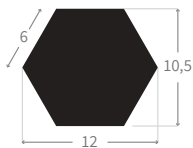

HEXA S
side 6 x 1

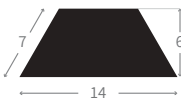

HALF HEXA M
base 14 x 1



HALF HEXA S
base 12 x 1

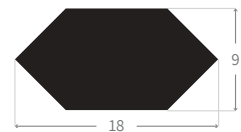

TRAP
18 x 9 x 1

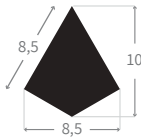

KITE
8,5 x 10 x 1

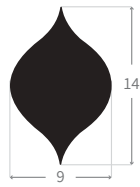

T-DROP
9 x 14 x 1

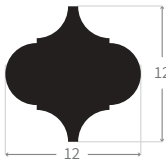

ARAB
12 x 12 x 1

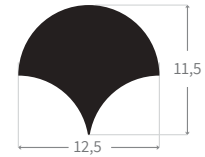

FISH SCALE
12,5 x 11,5 x 1

IN N' OUT

Mixing thicknesses 1 cm | 1,5 cm | 1,8 cm – available in all field tiles.

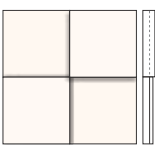

SQUARE
1 | 1,5 | 1,8

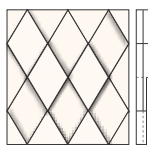

LOSA
1 | 1,5 | 1,8

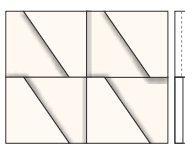

DUAL
1,2 | 1,8

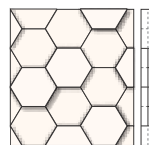

HEXA
1 | 1,5

NOTES

14 x 14, 11 x 11, 10 x 10 also available in 90° cut edge.
Glazed edges available by request.
All field tiles available in bisque.
Drawings not to scale.
Measurements denoted L x H x W in cm.
Tiles are handmade, size and shape variation can be expected.

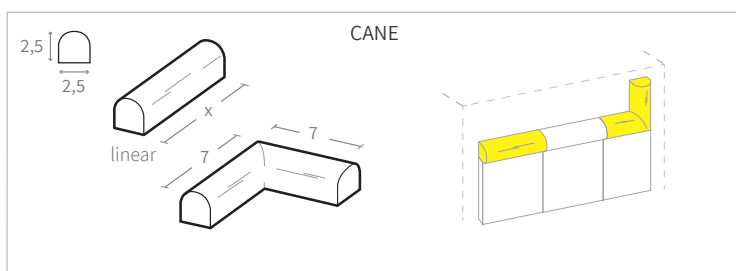
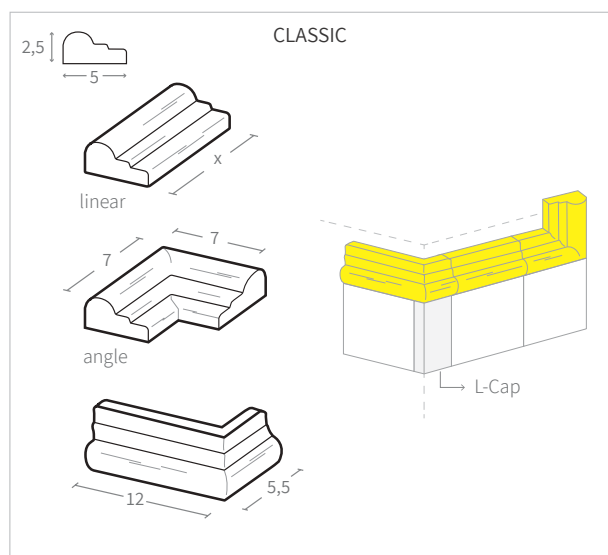
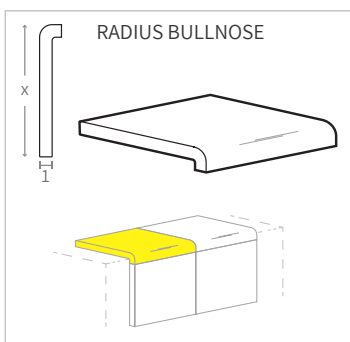
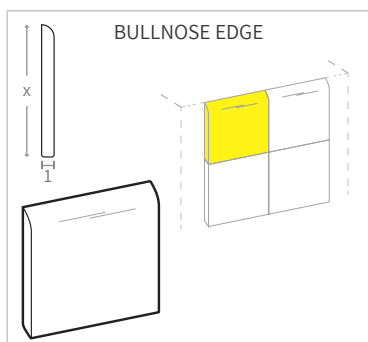
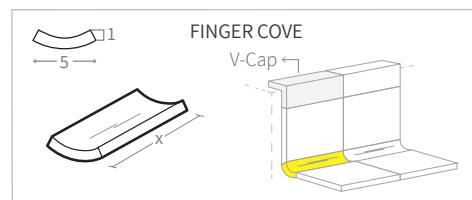
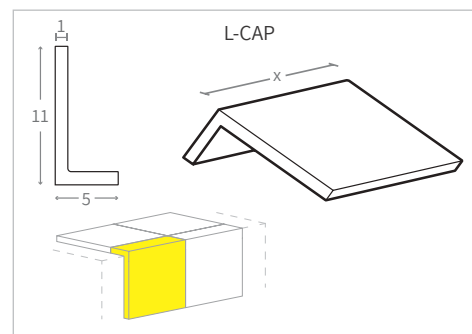
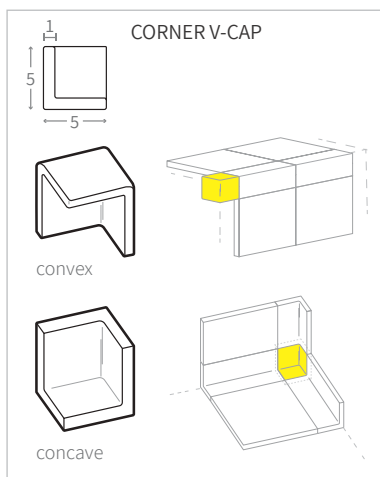
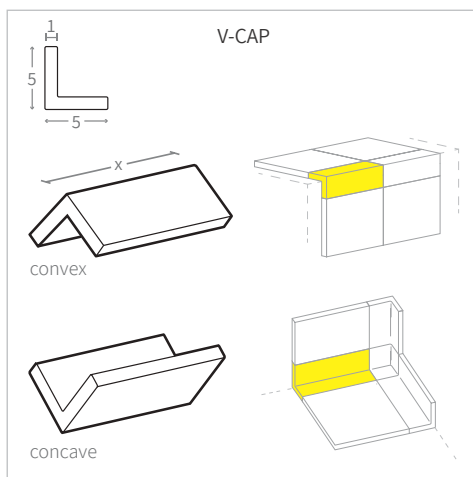

NOTES

Available for all field tiles.
 Bespoke corner tiles available by request.
 Glazed edges available by request.
 Drawings not to scale.
 Measurements denoted L x H x W in cm.
 Tiles are handmade, size and shape variation can be expected.

NEW MODERN



RETRO
24 x 8

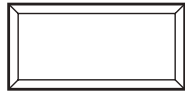

SUBWAY 1
15,5 x 7,5

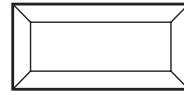

SUBWAY 2
15,5 x 7,5

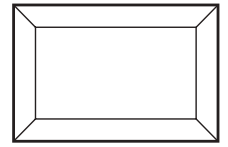

SUBWAY 3
18 x 12



BLOCK
20 x 8

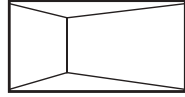

SKATER
15,5 x 8

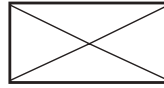

ENVELOPE
14 x 7

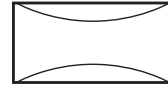

BUMP
14 x 7



KISS
14 x 7

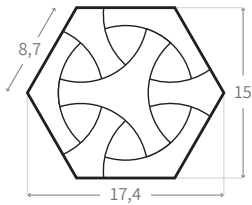

GLADIATOR
side 8,7

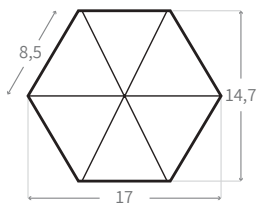

STAR
side 8,5

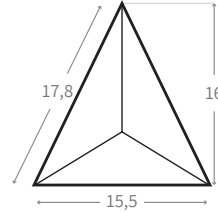

PYRAMIDE
15,5 x 16

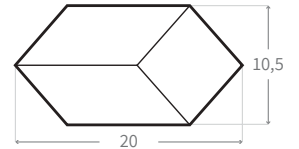

CONSTELLATION
20 x 10,5

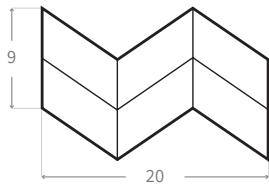

ZIG ZAG A
20 x 13,5

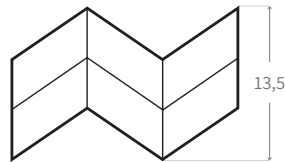

ZIG ZAG B
20 x 13,5



NAZCA A
20 x 8



NAZCA B
20 x 8



3D RECTANGLE
15 x 10



3D TRIANGLE 24
24 x 12

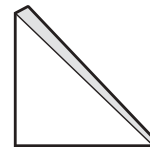

3D TRIANGLE 12
12 x 12

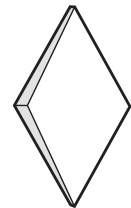

3D DIAMOND
10,5 x 18

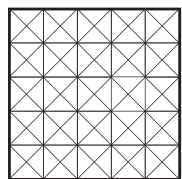

CUBIST
15 x 15

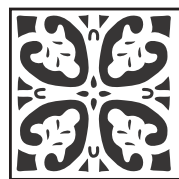

DÉCO
15 x 15

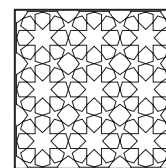

MARRAKESH
14 x 14

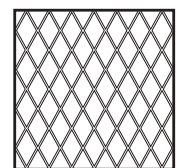

CAPITONNÉ
14 x 14

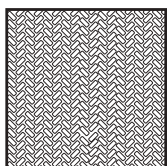

RAFIA
14 x 14

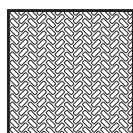

RAFIA
11 x 11

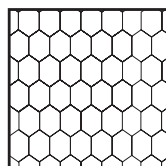

CAPOEIRA
14 x 14

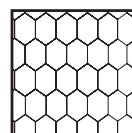

CAPOEIRA
11 x 11

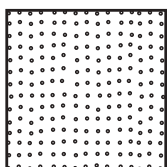

DOTS
14 x 14

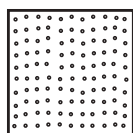

DOTS
11 x 11

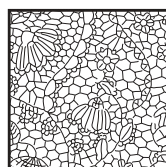

CROCHET
14 x 14

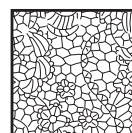

CROCHET
11 x 11

NOTES

Glazed edges available by request.

Drawings not to scale.

Measurements denoted L x H x W in cm.

Tiles are handmade, size and shape variation can be expected.

PORTUGUESE HERITAGE



ARRAIOS
14 x 14

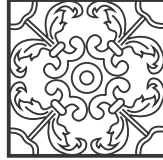

CALIFA
14 x 14



PARRA
14 x 14



BORDALLO
14 x 14



PINHEIRO
14 x 14

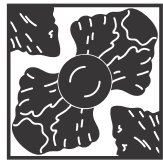

PENA
14 x 14



BOTÃO
13 x 13



FLORÃO
14,5 x 14,5



FLORÃO
11 x 11



RÉGUA
14 x 14



RÉGUA
11 x 11

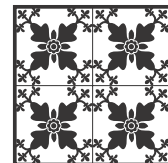

RENDA
14 x 14



RENDA
7 x 7

NOTES

Glazed edges available by request.

Drawings not to scale.

Measurements denoted L x H x W in cm.

Tiles are handmade, size and shape variation can be expected.

LAYOUTS

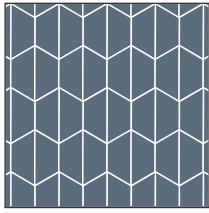

MONO 1
Half Hexa

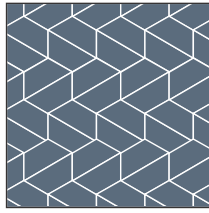

MONO 2
Half Hexa

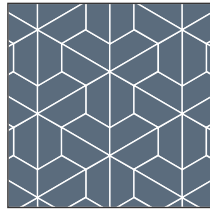

MONO 3
Half Hexa

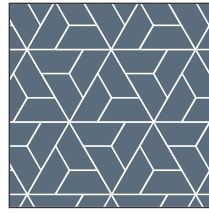

MONO 4
Half Hexa

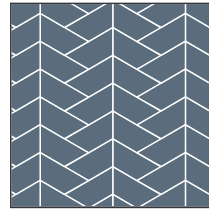

MONO 5
Half Hexa



MONO 6
Half Hexa

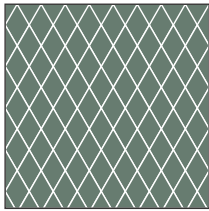

MONO 7
Losa

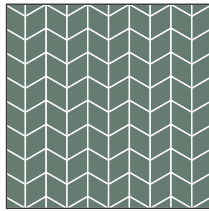

MONO 8
Losa

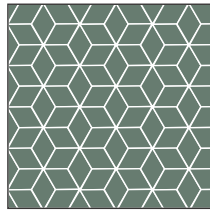

MONO 9
Losa

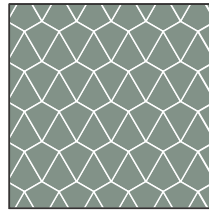

MONO 10
Kite

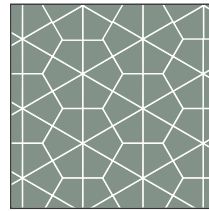

MONO 11
Kite

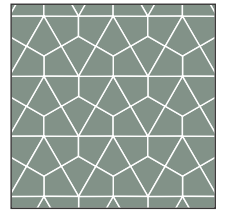

MONO 12
Kite

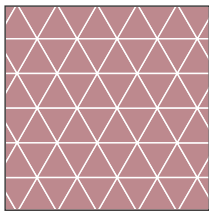

MONO 13
Tria

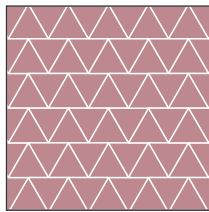

MONO 14
Tria

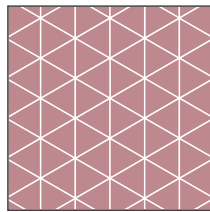

MONO 15
Tria

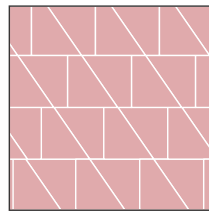

MONO 16
Dual 16

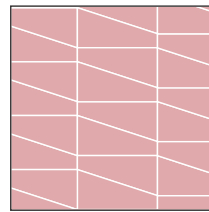

MONO 17
Dual 20

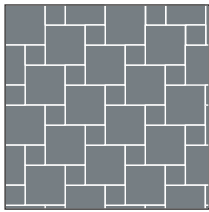

COMBO 1
Square

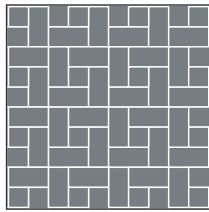

COMBO 2
Square & Half Square

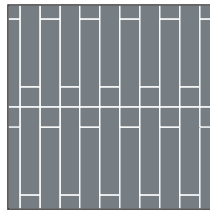

COMBO 3
Long & Square

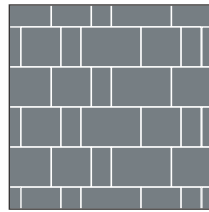

COMBO 4
Square & Rectangle
& Half Square

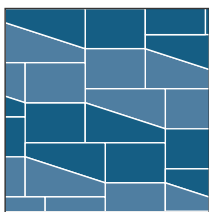

COMBO 5
Dual 20 &
Rectangle 10 x 15

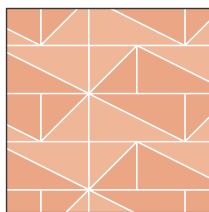

COMBO 6
Tria 90° M & Tria 90° S

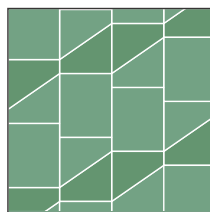

COMBO 7
Dual 16 &
Rectangle 16 x 13

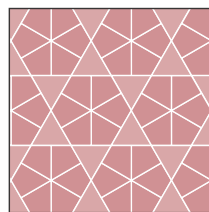

COMBO 8
Kite & Tria S

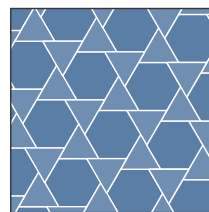

COMBO 9
Hexa M & Tria S

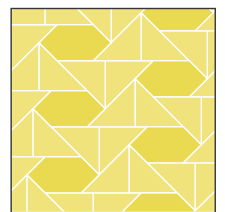

COMBO 10
Trap & Tria 90° S

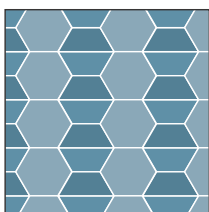

COMBO 11
Hexa & Half Hexa

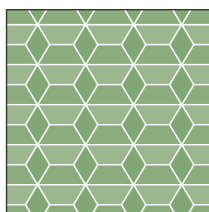

COMBO 12
Half Hexa S & Losa S

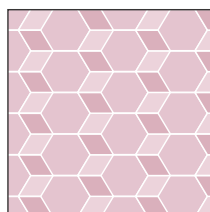

COMBO 13
Hexa S & Losa S

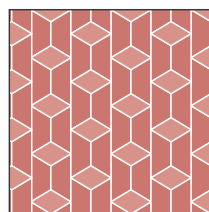

COMBO 14
Half Hexa S & Losa S

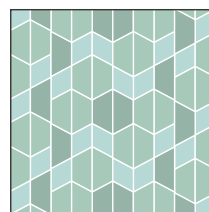

COMBO 15
Half Hexa S & Losa S

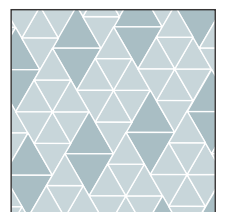

COMBO 16
Tria M & Tria S

TILES PER SQM

FIELD TILES			
in cm	number of tiles per sqm	in cm	number of tiles per sqm
Square 14 x 14 x 1 11 x 11 x 1 10 x 10 x 1 7 x 7 x 1 5 x 5 x 1	48 78 92 192 376	Tria M side 13 x 1 S side 10 x 1	136 230
Half Square 14 x 7 x 1 11 x 5,5 x 1 10 x 5 x 1	98 160 188	Losa M side 10,5 x 1 S side 6 x 1	104 320
		Hexa M side 7 x 1 S side 6 x 1	78 107
Rectangle 16 x 13 x 1,2 15 x 10 x 1 11 x 8 x 1	47 64 110	Half Hexa M base 14 x 1 S base 12 x 1	156 214
Long 30 x 10 x 1,2 30 x 7 x 1,2 22 x 5 x 1,2 20 x 8 x 1,2 20 x 4 x 1,2	33 47 86 60 118	Trap 18 x 9 x 1	86
		Kite 8,5 x 10 x 1	230
		T-Drop 9 x 14 x 1	148
		Arab 12 x 12 x 1	136
Dual 20 x 13 x 1,2 16 x 13 x 1,2	74 94	Fish Scale 12,5 x 11,5 x 1	134
Tria 90° M 24 x 12 x 1,2 S 12 x 12 x 1	70 138		

TRIMS			
in cm	number of tiles per linear m	in cm	number of tiles per linear m
V-Cap 14 x 5 x 1 11 x 5 x 1 10 x 5 x 1	7 9 10	Finger Cove 14 x 5 x 1 11 x 5 x 1 10 x 5 x 1	7 9 10
Corner V-Cap 5 x 5 x 1	—	Cane linear 14 x 2,5 11 x 2,5 10 x 2,5 angle side 7 x 2,5	7 9 10 —
L-Cap 14 x 14 x 1 11 x 11 x 1	7 9		
Bullnose Edge 14 x 14 x 1 11 x 11 x 1 10 x 10 x 1	7 9 10	Classic linear 14 x 5 11 x 5 10 x 5 angle side 7 x 5 corner 12 x 5,5 x 5	7 9 10 — —
Radius Bullnose 14 x 14 x 1 11 x 11 x 1 10 x 10 x 1	7 9 10		

NEW MODERN			
in cm	number of tiles per sqm	in cm	number of tiles per sqm
Subway 1. 15,5 x 7,5 2. 15,5 x 7,5 3. 18 x 12	86 86 46	3D Rectangle 15 x 10	66
Retro 24 x 8	52	3D Triangle 24. 24 x 12 12. 12 x 12	70 138
Block 20 x 8	62	3D Diamond 10,5 x 18	104
Envelope 14 x 7	102	Cubist 15 x 15	45
Bump 14 x 7	102	Déco 15 x 15	45
Kiss 14 x 7	102	Marrakesh 14 x 14	51
Skater 15,5 x 8	81	Capitonné 14 x 14	51
Constellation 20 x 10,5	62	Rafia 14 x 14 11 x 11	51 82
Pyramide 15,5 x 16	86	Capoeira 14 x 14 11 x 11	51 82
Star side 8,5	53	Dots 14 x 14 11 x 11	51 82
Gladiator side 8,7	51	Crochet 14 x 14 11 x 11	51 82
Zig Zag A 20 x 13,5 B 20 x 13,5	52 52		
Nazca A 20 x 8 B 20 x 8	62 62		

PORTUGUESE HERITAGE			
in cm	number of tiles per sqm	in cm	number of tiles per sqm
Arraiolos 14 x 14	51	Botão 13 x 13	59
Califa 14 x 14	51	Florão 14,5 x 14,5 11 x 11	48 82
Parra 14 x 14	51	Régua 14 x 14 11 x 11	51 82
Bordallo 14 x 14	51	Renda 14 x 14 7 x 7	51 204
Pinheiro 14 x 14	51		
Pena 14 x 14	51		

TILES PER SQM

COMBOS			
in cm	number of tiles per sqm	in cm	number of tiles per sqm
Combo 1 - A Square 14 x 14 Square 7 x 7	44 41	Combo 7 Dual 16 x 13 Rectangle 16 x 13	27 27
Combo 1 - B Square 10 x 10 Square 5 x 5	72 70	Combo 8 Kite 8,5 x 10 Tria S - side 10	180 63
Combo 2 - A Square 7 x 7 Half Square 14 x 7	25 95	Combo 9 Hexa M - side 7 Tria S - side 10	48 95
Combo 2 - B Square 5 x 5 Half Square 10 x 5	49 176	Combo 10 Trap 18 x 9 Tria 90° S - 12 x 12	28 102
Combo 3 - A Long 22 x 5 Square 5 x 5	80 70	Combo 11 - A Hexa M - side 7 Half Hexa M - base 14	43 85
Combo 3 - B Long 30 x 10 Square 10 x 10	25 25	Combo 11 - B Hexa S - side 6 Half Hexa S - base 12	60 103
Combo 3 - C Long 30 x 7 Square 7 x 7	44 37	Combo 12 Half Hexa S - base 14 Losa S - side 6	161 85
Combo 4 - A Square 10 x 10 Rectangle 15 x 10 Half Square 10 x 5	33 38 30	Combo 13 Hexa S - side 6 Losa S - side 6	67 136
Combo 4 - B Square 11 x 11 Rectangle 11 x 8 Half Square 11 x 5,5	39 41 38	Combo 14 Half Hexa S - base 14 Losa S - side 6	161 85
Combo 5 Dual 20 x 13 Rectangle 10 x 15	21 35	Combo 15 Half Hexa S - base 14 Losa S - side 6	177 78
Combo 6 Tria 90° M - 24 x 12 Tria 90° S - 12 x 12	52 47	Combo 16 Tria M - side 13 Tria S - side 10	44 172

Check the quantities.

Ordering proper quantities is essential as we cannot guarantee an exact match between batches.

We recommend ordering 10% extra tiles. There is a 3 sqm minimum order.

The number of tiles supplied per square meter is approximate and depends upon the suggested grout joint (our standing grouting space is 1 to 4 mm).

GLAZE COLOURS

**142 subtle, luminous, semi-transparent,
deep, metallic glazes.**

At New Terracotta, we are forging together the right balance
of pigment, glaze, history, science and emotion.

BASIC COLOURS



B301 Burnt Siena



B110 Antique Rose Velvet



B208 Giraffe Pink



B011 Flamingo Pink



B010 Flamingo Baby



B103 Pink Ballet



B101 Innocent Pink



B037 Soft Lilac



B150 Fresh Salmon



B007 Delicate Peach



B113 Frozen Margarita



B204 Giraffe Yellow



B092 Lemon Tart



B049 Pikachu Yellow



B001 Yellow Yolk



B053 Saffron Yellow



B054 Creme Caramel



B057 Brown Beer Bottle



B096 Desert Bisque



B097 Water Bisque



B059 Sand Bisque



B025 Oyster Mushroom White



B020 Vanilla Cream



B002 Eggshell White



B090 Penguin White



B202 Giraffe Print



B190 Transparent White

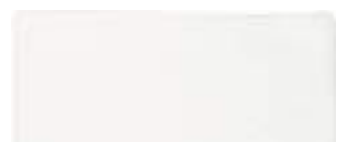

B091 Minimal White



B042 Ice Grey White



B043 French Grey



B044 Divine Grey



B029 Elephant Grey



B028 Charcoal Grey



B012 Jet Set Black



B705 So Sweet Teal



B017 Midnight Indigo

BASIC COLOURS



B014 Chicago Cobalt Blue



B069 Electric Blue



B023 Lavender Violet Blue



B061 Transparent Violet



B088 Tempest Blue



B083 Ocean Surf



B055 Blue Sky



B065 Misty Blue



B151 Blue Fronteira



B051 Blue Dolphin



B152 Blue Provence



B071 Paradise Turquoise



B074 Emerald Lake



B075 Ultramarine Sea



B039 Shallow Waters



B067 Spearmint Spa



B068 Crystal Blue Waters



B206 Giraffe Blue



B210 Giraffe Green



B022 Mint Macaron



B618 Amazon Green



B608 Green Delight



B600 Green Guru



B628 Khaki Green



B046 Green Mojito



B038 Neon Green



B625 Olive Green



B040 Forest Green



B089 Tempest Green



B700 British Racing Green

There may be some variation in the colours of the actual product. Tiles are handmade, shade variation can be expected.

MATT COLOURS



M815 Paper Black Matt



M820 Graphite Grey Matt



M865 Black Evergreen Matt



M845 Vintage Red Matt

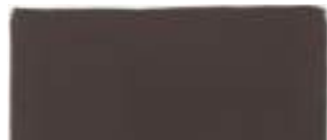

M800 Belgian Chocolate Matt



M810 Italian Coffee Matt

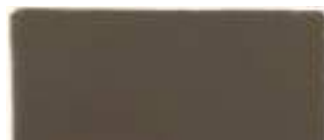

M860 Safari Green Matt



M835 Industrial Grey Matt



M825 Smoke Grey Matt



M885 Perfect Nude Matt



M875 Adorable Pink Matt



M880 True Rose Matt



M855 Elegant Greige Matt



M890 White Sand Matt



M830 Cotton White Matt



M850 Glaciar White Matt



M900 So Chic Teal Matt



M910 Historical Blue Matt



M925 Summer Blue Matt



M920 Forever Blue Matt



M915 Royal Blue Matt

There may be some variation in the colours of the actual product.
Tiles are handmade, shade variation can be expected.

OXIDE EXPLOSIONS



X023 Galaxy Explosion



X022 Petroleum Explosion



X010 Deep Blue Explosion



X011 Ocean Blue Explosion



X020 Mystery Teal Explosion



X021 Aqua Mist Explosion



X031 Soft Emerald Explosion



X044 Metallic Green Explosion



X042 Jungle Green Explosion



X050 Vibrant Bamboo Explosion



X060 Don Pesto Explosion



X061 El Guacamole Explosion



X033 Coralline Explosion



X071 Hazelnut Explosion



X032 Wisteria Blossom Explosion



X072 Classic Concrete Explosion



X074 Stylish Grey Explosion

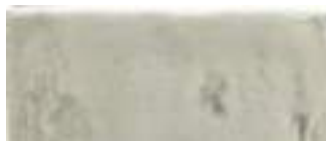

X075 Sophisticated Grey Explosion



X076 Wabi-Sabi Explosion

There may be some variation in the colours of the actual product.
Tiles are handmade, shade variation can be expected.

SPECIAL FIRING



S001 Red Chili Pepper



S010 Orange Caviar



S008 Acid Yellow



S018 Fresh Wasabi



S032 Yaya Carrot



S050 Red Tomato Delicious



S320 Pretty Red



S030 So Eggplant



S304 Du Vin Rouge



S380 Red Cobra



S381 Orange Cobra



S382 Yellow Cobra



S383 Funky Mint Cobra



S384 Spearmint Splash Cobra



S385 Violet Sunset Cobra



S390 Blue Gaudi



S393 Atlantic Blue Gaudi



S391 Green Gaudi



S392 Lime Gaudi



S394 Caribbean Green Gaudi



S340 Skinny Zucchini



S341 Caramel Spaghetti



S395 Salted Caramel Gaudi



S396 Lemon Sorbet Gaudi



S397 Dame Blanche Gaudi

There may be some variation in the colours of the actual product.
Tiles are handmade, shade variation can be expected.

VINTAGE METALLICS



V220 Olive Green



V210 Blush Copper



V240 Pink Mica



V200 Perfect Pearl



V012 Old Gold



V112 Old Gold Eruption

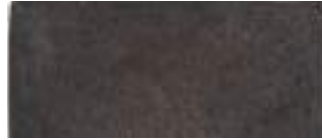

V018 Bronze Gold



V118 Bronze Gold Eruption



V009 Black Nickel



V109 Black Nickel Eruption



V006 Lava

There may be some variation in the colours of the actual product.
Tiles are handmade, shade variation can be expected.

GLAZE SPECIFICATION

New Terracotta has its core strength in the wide knowledge of colours. We are always ahead of different colour expressions.

A colour reaches its maximum when the pigment has been developed to the highest emotional resonance for that colour. There is so much more to our work than fine raw materials and high pigment loads. At New Terracotta, we are forging together the right balance of pigment, glaze, history, science and emotion.

The collection features 142 subtle, luminous, semi-transparent, deep, metallic colours. Each of them has a historical and artistic background.

BASIC COLOURS

Ref.	Colour Name	Glaze Definition	Glaze Variation	Long Term Crazing	Pools, Lakes Fountains	Exterior Facades
B001	Yellow Yolk	<i>glossy translucent</i>	<i>low</i>		✓	✓
B002	Eggshell White	<i>glossy translucent</i>	<i>low</i>		✓	✓
B007	Delicate Peach	<i>glossy translucent</i>	<i>moderate</i>		✓	✓
B010	Flamingo Baby	<i>glossy translucent</i>	<i>moderate</i>		✓	✓
B011	Flamingo Pink	<i>glossy translucent</i>	<i>moderate</i>		✓	✓
B012	Jet Set Black	<i>glossy solid</i>	<i>low</i>	<i>yes</i>	✓	✓
B014	Chicago Cobalt Blue	<i>glossy solid</i>	<i>low</i>	<i>yes</i>	✓	✓
B017	Midnight Indigo	<i>satin to glossy solid</i>	<i>low</i>		✓	✓
B020	Vanilla Cream	<i>glossy translucent</i>	<i>moderate</i>		✓	✓
B022	Mint Macaron	<i>glossy translucent craquelé</i>	<i>moderate</i>			
B023	Lavender Violet Blue	<i>glossy translucent</i>	<i>moderate</i>		✓	✓
B025	Oyster Mushroom White	<i>glossy translucent craquelé</i>	<i>moderate</i>			
B028	Charcoal Grey	<i>glossy solid</i>	<i>moderate</i>		✓	✓
B029	Elephant Grey	<i>glossy translucent</i>	<i>low</i>		✓	✓
B037	Soft Lilac	<i>glossy translucent</i>	<i>moderate</i>		✓	✓
B038	Neon Green	<i>glossy translucent</i>	<i>low</i>		✓	✓
B039	Shallow Waters	<i>glossy translucent craquelé</i>	<i>moderate</i>			
B040	Forest Green	<i>glossy translucent</i>	<i>moderate</i>	<i>yes</i>	✓	✓
B042	Ice Grey White	<i>glossy solid</i>	<i>low</i>		✓	✓
B043	French Grey	<i>glossy solid</i>	<i>low</i>		✓	✓
B044	Divine Grey	<i>glossy solid</i>	<i>low</i>		✓	✓
B046	Green Mojito	<i>glossy translucent craquelé</i>	<i>moderate</i>			
B049	Pikachu Yellow	<i>glossy solid</i>	<i>low</i>		✓	✓
B051	Blue Dolphin	<i>glossy translucent</i>	<i>moderate</i>		✓	✓
B053	Saffron Yellow	<i>glossy translucent</i>	<i>high</i>		✓	✓
B054	Crepe Caramel	<i>glossy translucent</i>	<i>high</i>	<i>yes</i>	✓	✓
B055	Blue Sky	<i>glossy translucent</i>	<i>low</i>		✓	✓
B057	Brown Beer Bottle	<i>glossy translucent</i>	<i>moderate</i>	<i>yes</i>	✓	✓
B059	Sand Bisque	<i>glossy translucent</i>	<i>moderate</i>		✓	✓
B061	Transparent Violet	<i>glossy translucent craquelé</i>	<i>high</i>			
B065	Misty Blue	<i>glossy translucent craquelé</i>	<i>moderate</i>			
B067	Spearmint Spa	<i>glossy translucent craquelé</i>	<i>high</i>			
B068	Crystal Blue Waters	<i>glossy translucent craquelé</i>	<i>moderate</i>			
B069	Electric Blue	<i>glossy solid</i>	<i>low</i>		✓	✓
B071	Paradise Turquoise	<i>glossy translucent craquelé</i>	<i>moderate</i>			
B074	Emerald Lake	<i>glossy translucent</i>	<i>moderate</i>		✓	✓
B075	Ultramarine Sea	<i>glossy translucent craquelé</i>	<i>high</i>			
B083	Ocean Surf	<i>glossy translucent</i>	<i>moderate</i>		✓	✓
B088	Tempest Blue	<i>glossy translucent</i>	<i>moderate</i>	<i>yes</i>	✓	✓
B089	Tempest Green	<i>glossy translucent</i>	<i>moderate</i>		✓	✓
B090	Penguin White	<i>satin to glossy solid</i>	<i>low</i>		✓	✓
B091	Minimal White	<i>glossy solid</i>	<i>low</i>		✓	✓
B092	Lemon Tart	<i>glossy translucent</i>	<i>moderate</i>		✓	✓

GLAZE SPECIFICATION

BASIC COLOURS

Ref.	Colour Name	Glaze Definition	Glaze Variation	Long Term Crazing	Pools, Lakes Fountains	Exterior Facades
B096	Desert Bisque	<i>glossy translucent</i>	<i>moderate</i>		✓	✓
B097	Water Bisque	<i>glossy translucent craquelé</i>	<i>moderate</i>			
B101	Innocent Pink	<i>glossy solid</i>	<i>low</i>		✓	✓
B103	Pink Ballet	<i>glossy solid</i>	<i>moderate</i>		✓	✓
B110	Antique Rose Velvet	<i>glossy translucent</i>	<i>low</i>		✓	✓
B113	Frozen Margarita	<i>glossy translucent craquelé</i>	<i>low</i>			
B150	Fresh Salmon	<i>glossy translucent</i>	<i>low</i>		✓	✓
B151	Blue Fronteira	<i>satin to glossy solid</i>	<i>low</i>		✓	✓
B152	Blue Provence	<i>satin to glossy solid</i>	<i>low</i>		✓	✓
B190	Transparent White	<i>glossy translucent craquelé</i>	<i>low</i>			
B202	Giraffe Print	<i>glossy translucent craquelé</i>	<i>moderate</i>			
B204	Giraffe Yellow	<i>glossy translucent craquelé</i>	<i>moderate</i>			
B206	Giraffe Blue	<i>glossy translucent craquelé</i>	<i>moderate</i>			
B208	Giraffe Pink	<i>glossy translucent craquelé</i>	<i>moderate</i>			
B210	Giraffe Green	<i>glossy translucent craquelé</i>	<i>moderate</i>			
B301	Burnt Siena	<i>glossy solid</i>	<i>low</i>		✓	✓
B600	Green Guru	<i>glossy solid</i>	<i>low</i>		✓	✓
B608	Green Delight	<i>glossy solid</i>	<i>low</i>		✓	✓
B618	Amazon Green	<i>glossy solid</i>	<i>low</i>		✓	✓
B625	Olive Green	<i>glossy solid</i>	<i>low</i>		✓	✓
B628	Khaki Green	<i>glossy solid</i>	<i>low</i>		✓	✓
B700	British Racing Green	<i>glossy translucent</i>	<i>moderate</i>	yes	✓	✓
B705	So Sweet Teal	<i>glossy solid</i>	<i>low</i>		✓	✓

MATT COLOURS

Ref.	Colour Name	Glaze Definition	Glaze Variation	Long Term Crazing	Pools, Lakes Fountains	Exterior Facades
M800	Belgian Chocolate Matt	<i>satin matt</i>	<i>low</i>		✓	✓
M810	Italian Coffee Matt	<i>satin matt</i>	<i>low</i>		✓	✓
M815	Paper Black Matt	<i>satin matt</i>	<i>low</i>		✓	✓
M820	Graphite Grey Matt	<i>satin matt</i>	<i>low</i>		✓	✓
M825	Smoke Grey Matt	<i>satin matt</i>	<i>low</i>		✓	✓
M830	Cotton White Matt	<i>satin matt</i>	<i>low</i>		✓	✓
M835	Industrial Grey Matt	<i>satin matt</i>	<i>low</i>		✓	✓
M845	Vintage Red Matt	<i>satin matt</i>	<i>low</i>		✓	✓
M850	Glaciar White Matt	<i>satin matt</i>	<i>low</i>		✓	✓
M855	Elegant Greige Matt	<i>satin matt</i>	<i>low</i>		✓	✓
M860	Safari Green Matt	<i>satin matt</i>	<i>low</i>		✓	✓
M865	Black Evergreen Matt	<i>satin matt</i>	<i>low</i>		✓	✓
M875	Adorable Pink Matt	<i>satin matt</i>	<i>low</i>		✓	✓
M880	True Rose Matt	<i>satin matt</i>	<i>low</i>		✓	✓
M885	Perfect Nude Matt	<i>satin matt</i>	<i>low</i>		✓	✓
M890	White Sand Matt	<i>satin matt</i>	<i>low</i>		✓	✓
M900	So Chic Teal Matt	<i>satin matt</i>	<i>low</i>		✓	✓
M910	Historical Blue Matt	<i>satin matt</i>	<i>low</i>		✓	✓
M915	Royal Blue Matt	<i>satin matt</i>	<i>low</i>		✓	✓
M920	Forever Blue Matt	<i>satin matt</i>	<i>low</i>		✓	✓
M925	Summer Blue Matt	<i>satin matt</i>	<i>low</i>		✓	✓

GLAZE SPECIFICATION

OXIDE EXPLOSIONS

Ref.	Colour Name	Glaze Definition	Glaze Variation	Long Term Crazing	Pools, Lakes Fountains	Exterior Facades
X010	Deep Blue Explosion	<i>glossy translucent</i>	<i>high</i>	yes	✓	✓
X011	Ocean Blue Explosion	<i>glossy translucent</i>	<i>high</i>	yes	✓	✓
X020	Mystery Teal Explosion	<i>glossy translucent</i>	<i>high</i>	yes	✓	✓
X021	Aqua Mist Explosion	<i>glossy translucent</i>	<i>high</i>	yes	✓	✓
X022	Petroleum Explosion	<i>glossy translucent</i>	<i>high</i>	yes	✓	✓
X023	Galaxy Explosion	<i>glossy translucent</i>	<i>high</i>	yes	✓	✓
X031	Soft Emerald Explosion	<i>glossy translucent</i>	<i>high</i>	yes	✓	✓
X032	Wisteria Blossom Explosion	<i>glossy translucent</i>	<i>high</i>	yes	✓	✓
X033	Coralline Explosion	<i>glossy translucent</i>	<i>high</i>		✓	✓
X042	Jungle Green Explosion	<i>glossy translucent</i>	<i>high</i>	yes	✓	✓
X044	Metallic Green Explosion	<i>glossy translucent</i>	<i>high</i>	yes	✓	✓
X050	Vibrant Bamboo Explosion	<i>glossy translucent</i>	<i>high</i>	yes	✓	✓
X060	Don Pesto Explosion	<i>glossy translucent</i>	<i>high</i>	yes	✓	✓
X061	El Guacamole Explosion	<i>glossy translucent</i>	<i>high</i>	yes	✓	✓
X071	Hazelnut Explosion	<i>glossy translucent</i>	<i>moderate</i>	yes	✓	✓
X072	Classic Concrete Explosion	<i>glossy translucent</i>	<i>moderate</i>	yes		
X074	Stylish Grey Explosion	<i>glossy translucent</i>	<i>moderate</i>	yes		
X075	Sophisticated Grey Explosion	<i>glossy translucent</i>	<i>moderate</i>	yes		
X076	Wabi-Sabi Explosion	<i>glossy translucent</i>	<i>moderate</i>	yes	✓	✓

SPECIAL FIRING

Ref.	Colour Name	Glaze Definition	Glaze Variation	Long Term Crazing	Pools, Lakes Fountains	Exterior Facades
S001	Red Chili Pepper	<i>glossy solid craquelé</i>	<i>moderate</i>		✓	✓
S008	Acid Yellow	<i>glossy solid craquelé</i>	<i>moderate</i>		✓	✓
S010	Orange Caviar	<i>glossy solid craquelé</i>	<i>moderate</i>		✓	✓
S018	Fresh Wasabi	<i>glossy solid craquelé</i>	<i>moderate</i>		✓	✓
S030	So Eggplant	<i>glossy translucent</i>	<i>moderate</i>		✓	✓
S032	Yaya Carrot	<i>glossy translucent</i>	<i>low</i>		✓	✓
S050	Red Tomato Delicious	<i>glossy translucent</i>	<i>low</i>		✓	✓
S304	Du Vin Rouge	<i>glossy solid</i>	<i>low</i>		✓	✓
S320	Pretty Red	<i>glossy solid</i>	<i>low</i>		✓	✓
S340	Skinny Zucchini	<i>glossy translucent craquelé</i>	<i>high</i>			
S341	Caramel Spaghetti	<i>glossy translucent craquelé</i>	<i>high</i>			
S380	Red Cobra	<i>reactive craquelé</i>	<i>moderate</i>		✓	✓
S381	Orange Cobra	<i>reactive craquelé</i>	<i>moderate</i>		✓	✓
S382	Yellow Cobra	<i>reactive craquelé</i>	<i>moderate</i>		✓	✓
S383	Funky Mint Cobra	<i>glossy translucent craquelé</i>	<i>moderate</i>			
S384	Spearmint Splash Cobra	<i>glossy translucent craquelé</i>	<i>moderate</i>			
S385	Violet Sunset Cobra	<i>glossy translucent craquelé</i>	<i>moderate</i>			
S390	Blue Gaudi	<i>glossy translucent craquelé</i>	<i>high</i>			
S391	Green Gaudi	<i>glossy translucent craquelé</i>	<i>high</i>			
S392	Lime Gaudi	<i>glossy translucent craquelé</i>	<i>high</i>			
S393	Atlantic Blue Gaudi	<i>glossy translucent craquelé</i>	<i>high</i>			
S394	Caribbean Green Gaudi	<i>glossy translucent craquelé</i>	<i>high</i>			
S395	Salted Caramel Gaudi	<i>glossy translucent craquelé</i>	<i>high</i>			
S396	Lemon Sorbet Gaudi	<i>glossy translucent craquelé</i>	<i>high</i>			
S397	Dame Blanche Gaudi	<i>glossy translucent craquelé</i>	<i>high</i>			

VINTAGE METALLICS

Ref.	Colour Name	Glaze Definition	Glaze Variation	Long Term Crizzling	Pools, Lakes Fountains	Exterior Facades
V006	Lava	metallic matt	low			
V009	Black Nickel	metallic glossy	low	yes	✓	✓
V012	Old Gold	metallic craquelé	moderate		✓	✓
V018	Bronze Gold	metallic craquelé	high		✓	✓
V109	Black Nickel Eruption	metallic glossy	low	yes	✓	✓
V112	Old Gold Eruption	metallic craquelé	moderate		✓	✓
V118	Bronze Gold Eruption	metallic craquelé	high		✓	✓
V200	Perfect Pearl	metallic matt	moderate			
V210	Blush Copper	metallic matt	moderate			
V220	Olive Bronze	metallic matt	moderate			
V240	Pink Mica	metallic matt	moderate			

Glaze Definition

All our craquelé is deliberately induced, usually known as artistic craquelé.

Glaze Variation

Glaze and texture variation is rated as follows:

Low - tile can vary slightly

Moderate - tile can vary slightly to moderately

High - tile can vary significantly

Very High - tile can show a large variation

Long Term Crizzling

According to Determination of Crizzling Resistance test results, EN ISO 10545-11 / ASTM C 424-93.

Pools, Lakes and Fountains

According to Determination of Crizzling Resistance test results, EN ISO 10545-11 / ASTM C 424-93; according to Determination of Chemical Resistance test results, EN ISO 10545-13 / ASTM C 650-04.

Exterior Facades

According to Determination of Frost Resistance test results, EN ISO 10545-12 (limit at - 20°C).

MATCHING GLAZES	Basic Colours 66	Matt Colours 21	Oxide Explosions 19	Special Firing 25	Vintage Metallics 11
Field Tiles	✓	✓	✓	✓	✓
Trims	✓	✓	-	✓	●
New Modern	✓	✓	-	✓	●
Portuguese Heritage	✓	✓	-	✓	●

● V006 Lava, V109 Black Nickel Eruption, V112 Old Gold Eruption, V118 Bronze Gold Eruption do not apply.

TILES SUITABILITY

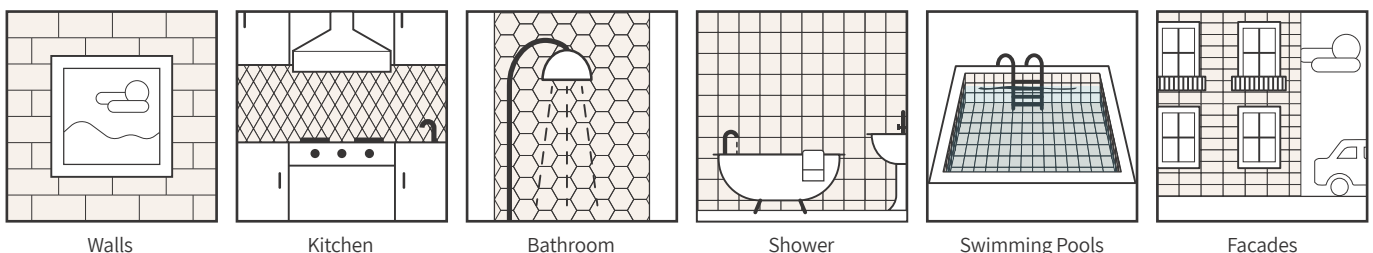

Please note that these are only recommendations and in some cases the tiles may be suitable for installation in additional spaces. Contact us for more information.



HAND PAINTED

**A stunning collection of historical
hand painted tiles.**

Timeless and durable, our reproduction hand painted tiles are a legacy with centuries of history as well as a delicious comeback.

HAND PAINTED PATTERNS



ÓBIDOS 14 x 14



COIMBRA 14 x 14



PORTO 14 x 14



LISBOA 14 x 14



ÉVORA 14 x 14



MONSARAZ 14 x 14



BELMONTE 14 x 14



LAMEGO 14 x 14



COLARES 14 x 14



SINTRA 14 x 14 | 11 x 11



FAIAL 14 x 14



PICO 14 x 14



ALCÁCER 14 x 14



CRATO 14 x 14



ESPINHO 14 x 14



TOMAR 14 x 14



TAVIRA 14 x 14



SAGRES 14 x 14



LAGOS 14 x 14



MELIDES 14 x 14

NOTES

Drawings not to scale.

Measurements denoted L x H x W in cm.

Tiles are handmade, size and shape variation can be expected.

HAND PAINTED PATTERNS



GOA 14 x 14



DIU 14 x 14



COCHIM 14 x 14



MALACA 14 x 14



TANGER 11 x 11



MOGADOR 11 x 11



AGADIR 14 x 14 | 11 x 11



CEUTA 14 x 14



BAHIA V 14 x 14



BAHIA R 14 x 14



BAHIA A 14 x 14



RIO 14 x 14 | 11 x 11



MINAS A 14 x 14

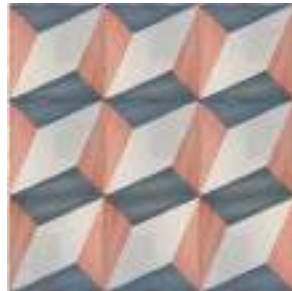

MINAS R 14 x 14

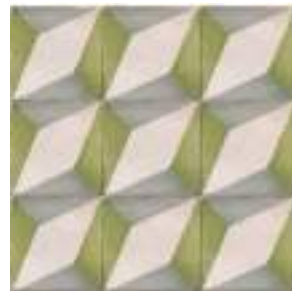

MINAS V 14 x 14

NOTES

Drawings not to scale.

Measurements denoted L x H x W in cm.

Tiles are handmade, size and shape variation can be expected.

HAND PAINTED PATTERNS

BORDERS



BORDER 1 14 x 14



BORDER 2 14 x 14



BORDER 3 14 x 14



BORDER 4 14 x 14

PATCHWORKS



PATCHWORK 1 14 x 14



PATCHWORK 2 14 x 14



PATCHWORK 3 14 x 14



PATCHWORK 4 14 x 14



PATCHWORK 5 14 x 14

RELIEFS



CALIFA HP 14 x 14



MARRAKESH HP 14 x 14



ANDALUCIA 14 x 14



PARIS 14 x 14

NOTES
 Drawings not to scale.
 Measurements denoted L x H x W in cm.
 Tiles are handmade, size and shape variation can be expected.

INSIDE THE ATELIER

**Extraordinary level of
customisation and collaboration.**

Our in-house team of designers, ceramic experts and experienced craftsmen allow us to collaborate with leading architects and designers on their spectacular projects.



HISTORIC RESTORATION

New Terracotta has considerable expertise and experience with tiles in listed buildings. We have delivered bespoke tiles to palaces, monuments, churches and private homes for projects involving very specific requests and requirements concerning quality, appearance and dimensions.

BESPOKE HAND PAINTED

Whether it is customising one of our existing designs, or working with us on a completely bespoke creation, our experts will guide you through this exciting process.

Using a variety of painting techniques, the glazes are applied which when fired create stunning individual pieces of ceramic art with tremendous depth of colour and character.

BESPOKE CLAY PIECES

Clay gives the freedom to create something intense, raw, over the top. It allows piling things up, breaking things down and making mistakes.

Playing with clay gives us room to take risks, get our hands dirty, explore new ideas and let ourselves dream.





GRANDE HOTEL LISBOA

SÃO PEDRO DO SUL, PORTUGAL

Field Tiles - Square 14 x 14 x 1 cm
Bespoke Hand Painted

photo by © Bárbara Reis

DESIGNERS AT HOME



Capitello by Elisa Passino

**We are proud to use our company
as a platform to showcase talent.**

Our approach is truly collaborative and experimental
with a clear delight in the process of working with others.



Recubed by Smink Things

Establishing a new dialogue between those who produce and those who create culture, New Terracotta is supporting and promoting the work of both established and emerging designers.

PURE LUX

Unique pieces of discreet luxury.

A very subtle approach to Jewellery, Pure Lux gold and platinum glazed pieces are elegant, stylish and distinct.



Quarter Florão
in Gold

Renda 7 x 7 cm
in Gold

Stripes 11 x 11 cm
in Gold + B091 Minimal White

Arraiolos 14 x 14 cm
in Gold + B014 Chicago Cobalt Blue

Losa S side 6 cm
in Gold

Bespoke Tria
in Gold

Tria S side 10 cm
in Gold

Stripes 14 x 14 cm
in Gold + B014 Chicago Cobalt Blue

Stripes 13 x 13 cm
in Gold + B014 Chicago Cobalt Blue

Stripes 10 x 10 cm
in Gold + B014 Chicago Cobalt Blue



Square 5 x 5 cm
in Bespoke Brush Gold

Florão 11 x 11 cm
in Gold + S001 Red Chili Pepper

Square 11 x 11 cm
in Gold + S001 Red Chili Pepper

Square 7 x 7 cm
in Gold + S001 Red Chili Pepper

Square 14 x 14 cm Smink Things
in Gold + Bespoke Black

Bespoke Relief 30 x 10 cm
in Gold

Botão 13 x 13 cm
in Gold

Square 5 x 5 cm
in Bespoke Brush Gold

Square 14 x 14 cm Smink Things
in Gold + Bespoke Orange



Square 11 x 11 cm
in Gold + S001 Red Chili Pepper

Square 5 x 5 cm
in Platinum + B014 Chicago Cobalt Blue

Square 5 x 5 cm
in Gold + S001 Red Chili Pepper

Cubist 15 x 15 cm
in Gold

Square 14 x 14 cm Smink Things
in Gold Matt + Bespoke Brown

Rafia 7 x 7 cm
in Bespoke Brush Gold

Long 22 x 5 cm
in Gold Matt + B067 Spearmint Spa

Califa 14 x 14 cm
in Gold + B014 Chicago Cobalt Blue

Rafia 14 x 14 cm
in Bespoke Brush Gold

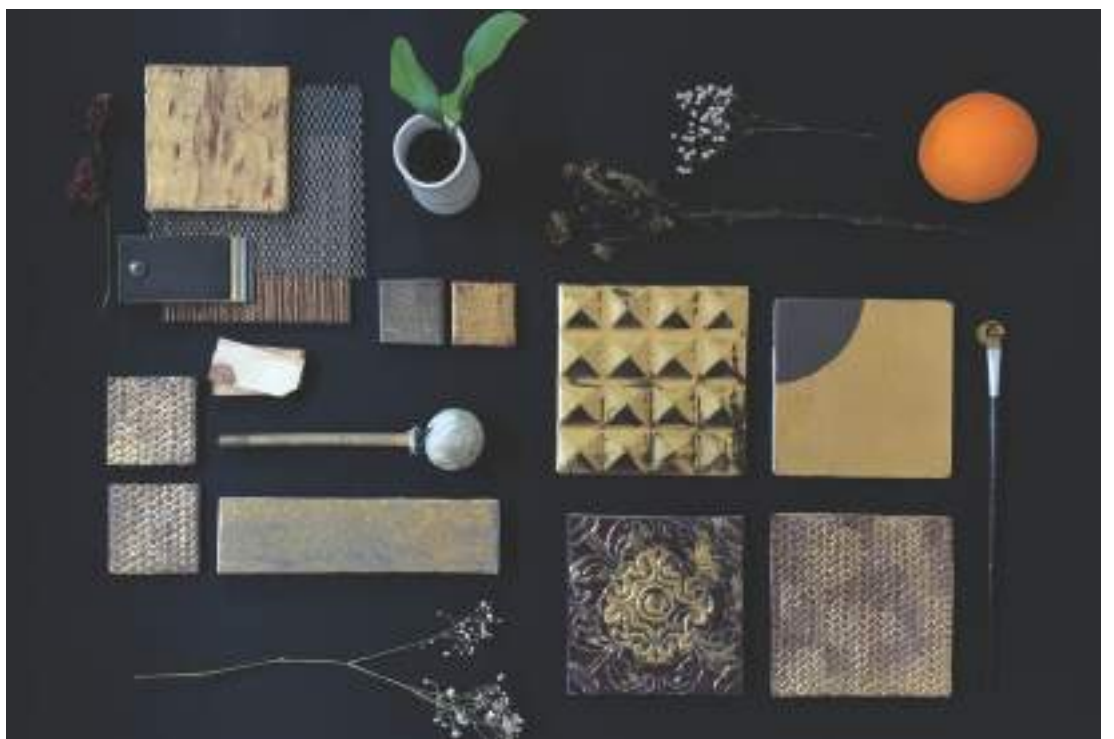





TECHNICAL GUIDE

We pride ourselves on supplying first class technical information and support to our clients.

All product technical values quoted are supported by laboratory testing from our own and independent ceramic test authorities.

PHYSICAL & CHEMICAL CHARACTERISTICS

Technical Features	Standards	Test Results	Compliance
 Determination of water absorption	EN ISO 10545-3	14,4 %	YES
	ASTM C 373-88	15,9 %	YES
 Determination of module of rupture	EN ISO 10545-4	R = 14,8 N/mm ² S = 1066 N	YES
 Determination of frost resistance	EN ISO 10545-12	Not affected	YES
 Determination of chemical resistance Household Chemicals Swimming Pool Salts Acids Alkali	EN ISO 10545-13	Class A	YES
	ASTM C 650-04	Not affected	YES
 Determination of resistance to staining Green Chromium Iodine Olive Oil	EN ISO 10545-14	Class 5	YES
	ASTM C 1378-04	Not affected (limit at -20°C)	YES

New Terracotta Handmade Glazed Tiles, Group III.
 Test report, CTCV - Centro Tecnológico da Cerâmica e do Vidro.

We have the ability to do PTV tests (Pendulum Test Values) as well as LRV tests (Light Reflectance Values).



Recycling
 New Terracotta glazed tiles contain 25% to 28% recycled materials, depending on the product type.

New Terracotta Tile Collection is suitable for most interior and exterior applications, including residential and commercial floors, walls, counters, showers, bathrooms, swimming pools, spas and fountains. Because the purchase of New Terracotta Tile for your home or commercial project represents an important investment, proper installation and maintenance is critical.

TILE UNDERSTANDING

It is important to understand that the differences in colour, shape, size, texture and moisture absorption are the unique characteristics that distinguish each of these tile products.

Glazed Tile

A coloured, liquid glaze is applied to the surface of a clay body.

The tile is fired in a kiln at very high temperatures of more than 1.050 °C .

The glazing process defines the colour and surface texture and produces a hard, non-porous, impermeable tile with a very low water absorption rate.

Glazed tiles are easier to clean and any liquid on its surface will drain faster.

Size and Length Variation

Our tiles shrink during the production process.

You can expect some variation, especially on longer tiles.

Lengthwise Bowing and Surface Undulation

Clay is an elastic material, therefore it will attempt to regain its original shape as it moves through the production process. For this reason, you can expect both an acceptable amount of lengthwise bowing and a surface undulation.

Undulation can occur anywhere on the surface and could include a slightly raised corner or edge.

Colour and Glaze Variation

Shade variation is inherent in all fired ceramic products and certain tiles will show greater variation within their dye lots.

We assign all our glazes with a low, moderate, high or very high rating. See our Glaze Guide for a complete description of glaze characteristics.

Glazing on relief tiles will vary in thickness and as a result the glazing may appear darker and lighter in different areas throughout the tile.

TILE PREPARATION

Meticulously plan your layout. The time you take for preparation and placement will greatly impact the finished result.

- Pre-sort your tile by colour and size so you can distribute the range of variation throughout the installation.
- Blending is recommended.
- Inspect each tile for cracks or other deformities that make its use inappropriate for the application intended.

TILE GROUTING

We advise a grout joint (1 to 4 mm) which joins the tiles so that they touch one another with an irregular space left between tiles, created by the imperfection of the edges.

Grout joint width can be varied to adjust tile alignment with adjacent handmade tiles or other architectural elements.

Give design consideration to the grout colour as it relates to the colour of tile chosen. There may be a desire to accentuate the tile with a border of contrasting grout colour. To more closely connect each tile with each other, use a grout colour in a hue that approximates the colours found in the tile.

INSTALLATION & MAINTENANCE

TILE INSTALLATION

Install per industry standards for terracotta glazed tiles.

Proper substrate preparation and the right choice of adhesives and grouts for the type of tile and specific project conditions are critical for achieving a long-lasting installation. New Terracotta tiles can be installed with any conventional tiling method, using any mortars, adhesives (EN 1200 C2) and grout compounds (EN 13888) suitable for use with wall tiles.

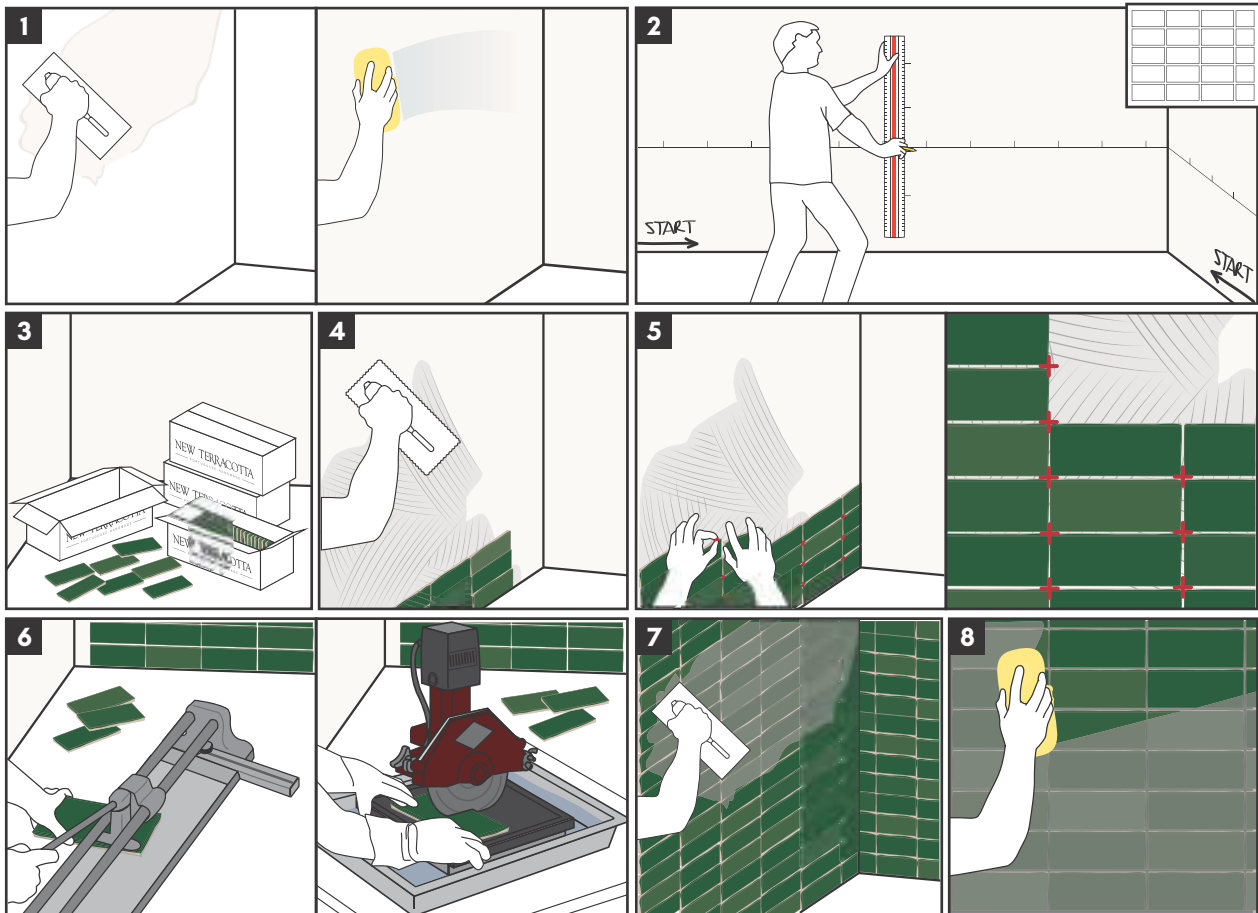

1. **Prepare the surface.** Substrate must be clean, leveled and adequately set.
2. **Determine the layout and mark the surface.** For aesthetic and technical optimisation, define starting points and cuttings.
3. **Distribute the tiles.** Pre-sort your tile by colour and size so you can distribute the range of variation throughout the installation.
4. **Apply the proper tile adhesive.** Use a large-toothed trowel to spread the adhesive.
5. **Install the tiles.** Lay down tiles by lining them up and pressing them firmly into the adhesive. Installation is easier if you use X-shaped tile spacers.
6. **Cut the tiles.** If some tiles need to be trimmed, you can use either a snap tile cutter or a wet tile saw.
7. **Grout the joints.** Allow the adhesive to cure for about 24 hours and then fill in the joints with the selected grout, using a rubber grout float.
8. **Clean the tiles after grouting.** The excess grout must be cleaned immediately with a wet sponge, rinsing often.

MAINTENANCE

New Terracotta Tile is a relatively maintenance-free product that requires little continuing care beyond regular cleaning. Continued beauty and performance of our tiles is assured by following these recommendations:

- For everyday cleaning, simply use a pH-balanced natural cleaner diluted in warm water.
- To clean stubborn spots or grout joints use a stiff natural bristle brush.
- Always avoid the use of abrasive cleaning pads or products containing bleach, ammonia and paint thinner.
- Never scrub with rough materials, such as hard brushes or wire wool, which may scratch the surface.
- In cooking areas, around a stove, on counters and backsplashes, cooking oil splatters should be cleaned as soon as possible as oil may darken some tiles.

12 QUESTIONS TO ASK BEFORE INSTALLING YOUR TILES

ARE ALL YOUR TILES SUITABLE FOR ALL PURPOSES?

No. Some glazes are recommended for walls only. Some glazes are not suitable for use in swimming pools. Please check for usage information in Glaze Guide.

CAN I MIX DIFFERENT COLOURS AND SIZES?

Many shapes and sizes can be used together. Please check Layouts information in Format Guide.

WILL SETTING TILES ON A DIAGONAL REQUIRE MORE MATERIAL?

Yes, typically more material is required when tile is set on a diagonal versus a straight-set. Please refer to your installer when determining how much material is needed.

WHAT SIZE DO YOU SUGGEST FOR GROUT SPACING?

New Terracotta tiles are sized to accommodate a 1 to 4 mm grout space, depending on the format. Many factors determine the size of a grout joint. It is important to discuss this with both your architect and installer and follow a jointing scheme.

DO I NEED TO SEAL THE GLAZED TILES?

In general, our tiles do not require sealing. However, tiles with craquelé glazes, in certain installations, should be sealed prior to grouting.

CAN I USE YOUR TILES AROUND THE FIREPLACE? ARE THEY HEAT-RESISTANT?

Our tiles are fired in kilns at very high temperatures. They can be used in fireplace installations and will not be damaged by heat.

CAN I USE YOUR TILES IN THE SHOWER?

Yes, our tiles are suitable for wet applications. Please note that in regularly wet areas, such as showers, it is common for some tiles to darken and lighten as they become wet and then dry.

WHAT TILES CAN I USE IN A POOL OR FOUNTAIN?

We have several glazes suitable for pools. Please check for usage information in Glaze Guide.

CAN I USE YOUR TILES IN EXTERIOR APPLICATIONS?

We have had our tiles installed outside on vertical surfaces for several years now with no issues. We do not recommend using our tile outside on horizontal surfaces. Please contact us and we will help determine the suitability of our tiles for your exterior installation.

IS TILING WITHOUT GROUTING POSSIBLE?

In practice, tiling without grouting is not recommended. Even for cut edge tiles, minimum 1 mm and better yet, 2 mm grouting is recommended.

WHAT IS THE BEST WAY TO CLEAN MY TILES?

For everyday cleaning, simply use a pH-balanced natural cleaner to care for your tiles. We do not recommend the use of any acids to clean our tiles and it is always wise to test any other cleaning methods in an inconspicuous area of your installation.

HOW SHOULD I CLEAN MY GOLD AND PLATINUM GLAZED TILES?

Exactly the same way as per the other glazed tiles. Always avoid the use of abrasive cleaning pads.







NATURAL COTTO

New Terracotta cotto tiles are made by hand using a slow but simple process which has been employed since Roman times. Using only natural raw materials, each tile is hand-moulded, dried on a wooden bat and then wood fired for about 48 hours to well over 1000°C, becoming resistant to very low temperatures. Our full of character cotto is not absolutely uniform, but vary slightly in shape, size and shade. Its natural warm tone and depth of colour will age beautifully, acquiring the attractive patina so much desired for a timeless appearance.

28 Formats | 4 Colours

FORMATS

**28 sizes and shapes designed to cater
any aesthetic, scale and function.**

Playing with formats and patterns will determine the look of the project, from classic and quiet to dynamic and contemporary.

FIELD TILES



SQUARE
38 x 38 x 2



SQUARE
29 x 29 x 2



SQUARE
24 x 24 x 2*



SQUARE
20 x 20 x 2*



SQUARE
15 x 15 x 1,5



SQUARE
11 x 11 x 1,5



SQUARE
7 x 7 x 2*



RECTANGLE
38 x 18 x 2



RECTANGLE
29 x 14 x 2

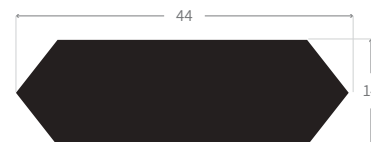

TRAP M
44 x 14 x 2*



LONG
55 x 13 x 2



LONG
29 x 7 x 2*

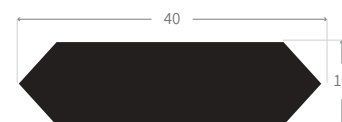

TRAP S
40 x 10 x 2*



CHEVRON A
38 x 10 x 2*



CHEVRON B
38 x 10 x 2*

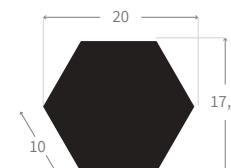

HEXA
side 10 x 2*

BRICKS



24 x 11 x 2



24 x 5 x 11



24 x 6,5 x 4 cut



24 x 4 x 2



24 x 5 x 2

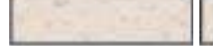

24 x 6,5 x 2 cut

NOTES

*Lower thickness available by request (minimum 1,5 cm).

Drawings not to scale.

Measurements denoted L x H x W in cm.

Tiles are handmade, size and shape variation can be expected.

SPECIAL TILES



FULL BULLNOSE CORNER
40 x 40 x 2

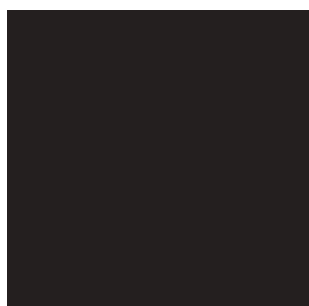

RADIUS BULLNOSE
40 x 40 x 2



RADIUS BULLNOSE
30 x 40 x 2



SKIRTING - CUT EDGE
40 x 10 x 2



SKIRTING - CUT EDGE
30 x 7 x 2



SKIRTING - BULLNOSE EDGE
30 x 9 x 2

TILES PER SQM

FIELD TILES			
in cm	number of tiles per sqm	in cm	number of tiles per sqm
Square		Chevron	
38 x 38 x 2	7	A 38 x 10 x 2	24
29 x 29 x 2	12	B 38 x 10 x 2	24
24 x 24 x 2	17	Trap	
20 x 20 x 2	25	M 44 x 14 x 2	21
15 x 15 x 1,5	45	S 40 x 10 x 2	25
11 x 11 x 1,5	81	Hexa	
7 x 7 x 2	198	side 10 x 2	33
Rectangle		Brick	
38 x 18 x 2	15	24 x 11 x 2	36
29 x 14 x 2	25	24 x 4 x 2	95
		24 x 5 x 11	75
Long		24 x 5 x 2	75
55 x 13 x 2	14	24 x 6,5 x 4 cut	58
29 x 7 x 2	49	24 x 6,5 x 2 cut	58

SPECIAL TILES			
in cm	number of tiles per linear m	in cm	number of tiles per linear m
Step & Pool Edge		Skirting	
Full Bullnose Corner 40 x 40 x 2	—	Cut Edge 40 x 10 x 2	2,5
Radius Bullnose 40 x 40 x 2	2,5	Cut Edge 30 x 7 x 2	3,3
Radius Bullnose 30 x 40 x 2	3,3	Bullnose Edge 30 x 9 x 2	3,3



CLAY COLOURS

**4 warm, distinctive, rich clay colours
that will age beautifully.**

At New Terracotta, we are merging the alchemy of simple elements
earth, water, air and fire with our aesthetic emotion



N002 Terra Sand

Grade V1



N004 Terra Firing

Grade V3



N006 Terra Classic

Grade V2



N008 Terra Brown

Grade V1

COLOUR SHADE VARIATION GRADING

Variation in colour and shade texture is an inherent characteristic of any fired cotto and certain tiles will show greater variation within their lots.

V1. Uniform Appearance — minimal to no difference among pieces from the same production run.

V2. Slight Variation — distinguishable differences in texture and shades within similar tiles.





V3. Moderate Variation — random colour variation from tile to tile, so that one tile may have a different colour from that on other tiles.



TECHNICAL GUIDE

We pride ourselves on supplying first class technical information and support to our clients.

All product technical values quoted are supported by laboratory testing from our own and independent ceramic test authorities.

PHYSICAL & CHEMICAL CHARACTERISTICS

FIELD TILES			
Technical Features	Standards	Test Results	Compliance
 Determination of water absorption	EN ISO 10545-3	<u>Terra Classic</u> 21% <u>Terra Sand</u> 25%	YES
 Determination of module of rupture	EN ISO 10545-4	<u>Terra Classic</u> R = 6 N/mm ² S = 1680 N <u>Terra Sand</u> R = 6 N/mm ² S = 1590 N	YES
 Determination of resistance to deep abrasion	EN ISO 10545-6	<u>Terra Classic</u> 2137 mm ³ <u>Terra Sand</u> 2390 mm ³	YES
 Determination of slip resistance (Pendulum)	ENV 12633	<u>Terra Classic</u> 83 USRV <u>Terra Sand</u> 90 USRV	YES

BRICKS			
Technical Features	Standards	Test Results	Compliance
 Determination of water absorption	EN ISO 10545-3	<u>Terra Firing</u> 19% <u>Terra Sand</u> 22%	YES
 Determination of compressive strength	EN 772-1	<u>Terra Firing</u> 30,6 N/mm ² <u>Terra Sand</u> 19,7 N/mm ²	YES
 Determination of frost resistance	UNE 67-028-97	Not affected (limit at -5°C)	YES

New Terracotta Handmade Unglazed cotto Tiles, Group III.
Test report November 2010, ITC - Instituto de Tecnología Cerámica

Please note these tips are guides only and should be used in addition to the relevant industry standards for cotto tiles. Note that installation may vary from site to site with varying conditions experienced on site (i.e. soil conditions, pool surrounds, driveways, wet areas etc.). The contractor and specifier should decide if these suggestions are suitable for their application or require further adjustment.

TILE UNDERSTANDING

New Terracotta produces handmade cotto tiles according to ancient traditions. It is important to understand that the differences in colour, shape, size, texture and moisture absorption are the unique characteristics that distinguish each of these tiles.

Size and Length Variation

Our tiles shrink during the production process. You can expect some variation, especially on longer tiles.

Lengthwise Bowing and Surface Undulation

Clay is an elastic material; therefore it will attempt to regain its original shape as it moves through the production process. For this reason, you can expect both an acceptable amount of lengthwise bowing and a surface undulation. Undulation can occur anywhere on the surface and could include a slightly raised corner or edge.

Shade Variation

Shade variation is inherent in all fired ceramic products and certain tiles will show greater variation within their fired lots.

Efflorescence

The term efflorescence means the migration of salts to the surface of the cotto tiles. Efflorescence originates from the terracotta itself, from the ground, concrete, polluted rain or by poorly executed acid washes. Since the clay we use is 100 % natural, different efflorescence is likely to appear after the laying process. In order to remove efflorescence, possible remains of sand and stucco smears, a floor washing is needed before any kind of floor treatment. The washing is made through a specific buffered acid followed by a rinse with clean water.

TILE PREPARATION

Meticulously plan your layout. The time you take for preparation and placement will greatly impact the finished result.

- Pre-sort your tile by shade and size so you can distribute the range of variation throughout the installation.
- Blending is recommended.
- Inspect each tile deformities that make its use inappropriate for the application intended.
- Both sides of the tiles should be wipe clean of any dust before installation.
- The tiles can be cut using a diamond-blade (ideally a water-cooled machine).

TILE LAYING

The laying of New Terracotta cotto can be carried out with many patterns also by mixing different formats, using a mixture of sand and cement screed, dusted with wet cement or by using adhesive, a more reliable and simple method. The most recent developments in technology in the field of adhesives offer biocompatible materials, excellent for combining with our organic products.

Slope — Laying Outdoors

For laying outdoors we recommend to keep the correct slope to prevent water stagnation.

When dealing with outdoor flooring, special attention must be paid during planning in order to respond adequately to rainwater run-off. This is done by dividing the floor field into different drainage surfaces, giving them effective slope and perfect levelness.

This will avoid trapping water and moisture on the floor surface since they cause undesirable and unsightly effects due to rings, saltpetre efflorescence and dirt build up.

INSTALLATION & MAINTENANCE

Laying General Methods:

- 1. Prepare a sub floor** (screed) that is perfectly flat to make it easy to keep the cotto tiles leveled with each other (therefore offering the necessary laying tolerances).
- 2. Clean the laying surface** (remove debris, dust, oil, etc), once the screed is completely dry.
- 3. Prepare a uniform layer of adhesive** (8 to 10 mm thick) using a notch trowel and back butter the base of the tile as well.
- 4. Lay the cotto tiles** so the timing corresponds to the drying time required for the adhesive used.
- 5. Compact the cotto tiles** evenly on the adhesive with a rubber mallet to ensure consistent contact. Consistent open joints should be allowed for at 4 to 6 mm spacing.

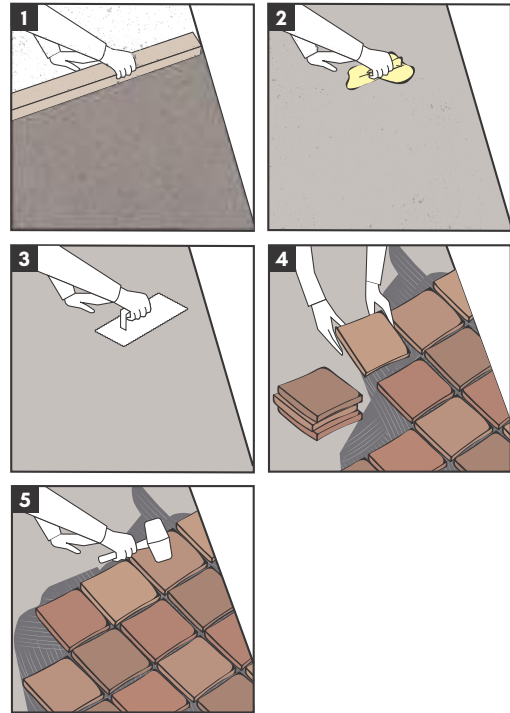

TILE SURFACE PREPARATION BEFORE SEALING AND GROUTING

Once the adhesive dry, clean the surface by scrubbing it using a neutral detergent diluted with water. It will remove any dust and dirt that may have accumulated during the installation process. Rinse thoroughly with clean water and leave to dry.

Tiles should then be allowed to set for 48 hours before applying sealant and grout.

TILE SEALING BEFORE GROUTING

An impregnating sealing is an essential step in protecting the beauty and ensuring the longevity of cotto tiles, as it accentuates the inherent clay colour and helps to protect against fading and staining.

The sealant is a solvent based liquid that limits water and oil penetration. It impregnates the tile, protects it and keeps its natural matt aspect.

New Terracotta prefers and recommends the use of water based products, which are more natural and chemically less invasive and are therefore in line with organic products.

- Apply with a brush or a roller on a dry and clean surface.
- Do not apply too much. The excess would leave glistening stains on the surface (brush traces).
- Always try the sealer on a loose tile before applying it on the entire surface in order to measure the grade of absorption of the tiles.

INSTALLATION & MAINTENANCE

TILE GROUTING

It is recommended to use a high-grade pre-bagged grouting compound suitable for the application. Grout joint width can be varied to adjust tile alignment with adjacent tiles or other architectural elements.

Grouting General Methods:

- 1. Dampen grout joints and tile with a sponge.**
 - 2. Grout the joints**, ensuring no voids, to the full depth of the paving tiles.
 - 3. Remove excess grout** with a trowel. If any residue remains on the face of the tile a scouring pad or a fine-grained sandpaper can be used to gently remove it.
 - 4. Clean the paving surface** with water, ensuring all excess grout has been removed.
- Never use acidic cleaners, strong detergents or bleach as these will damage the tiles. Stains or spots can be delicately removed with a scouring pad or fine-grained sandpaper.

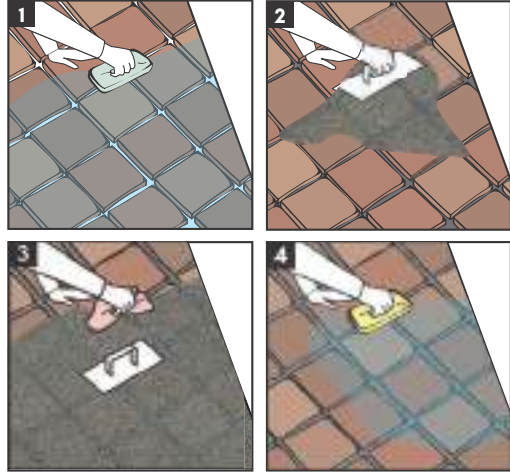

FINISHING AFTER GROUTING

The finishing completes the protection against wear and dirt. It gives the cotto tile the desired final appearance, as it revives the colours of the natural cotto.

Always apply a final coat of impregnating sealant making sure to cover the grout joints as well.

Further to the above you can also apply a surface wax or oil. This will offer extra protection and give an attractive patina.

Mostly used are natural bee waxes either liquid or paste, or specific floor oils. There are various sheens; brilliant gives a shiny appearance, matt keeps the look natural or satin gives a coating between the two.

A finishing wax or oil is not applied on external floors as it would not last long when exposed to weathering. In these situations only a water repellent or oil repellent is applied.

MAINTENANCE

Keep the surface as free as possible of loose dust and grit with regular vacuuming or sweeping. This will reduce the sandpaper effect of dirt getting compacted into the surface and joints.

Wash the floor using a pH neutral cleaner (ideally biodegradable and environment friendly) to remove the dirt that a vacuum won't pick up and for hygiene purposes.

We strongly recommend avoiding the use of bleach based cleaners, washing-up liquids or any other acid cleaners.

8 QUESTIONS TO ASK BEFORE INSTALLING YOUR TILES

ARE ALL YOUR TILES SUITABLE FOR ALL PURPOSES?

No. High porosity is one of the cotto tile characteristics. For this reason we do not recommend cotto tiles for pools, fountains nor shower flooring.

WHERE CAN I USE NEW TERRACOTTA COTTO TILES?

Fired to extremely high temperatures, the tiles are resistant to frost and excellent to store heat, making them suitable for both indoor and outdoor applications. Being non-slip and hardwearing they are also ideal for conservatories, patios and swimming pool areas.

CAN I USE YOUR TILES AROUND THE FIREPLACE? ARE THEY HEAT-RESISTANT?

Our tiles are wood fired at very high temperatures. They can be used in fireplace installations and will not be damaged by heat.

CAN I USE UNDERFLOOR HEATING WITH NEW TERRACOTTA COTTO TILES?

One of the major advantages of terracotta tiling is that they are the highest recommended floor covering to use in conjunction with underfloor heating. During tiling, appropriate expansion gaps should be left between tiles by the edges of the wall, at certain intervals to cover up shrinkage and expansion caused by the floor.

IS TILING WITHOUT GROUTING POSSIBLE?

Tiling without grouting is not recommended.

WHAT SIZE DO YOU SUGGEST FOR GROUT SPACING?

New Terracotta cotto tiles are sized to accommodate a 4 to 6 mm grout space. Many factors determine the size of a grout joint. It is important to discuss this with both your architect and installer and follow a jointing scheme.

ARE NEW TERRACOTTA COTTO TILES PRE-SEALED?

We always send our tiles in a natural state, therefore they must be always sealed upon installation. When needed, the necessary treatment products can be sent along with the material but they would have to be applied on site.

DO I NEED TO SEAL THE COTTO TILES?

Yes. Sealing is essential to protect the beauty and ensure the longevity of any cotto tile.

COMMERCIAL SUPPORT

Our aim is to enable our clients to access key
commercial information.

FREQUENTLY ASKED QUESTIONS

■ PLACING AN ORDER

CAN I BUY ONLINE?

We are not prepared to sell directly through our website. For ordering tiles, custom requests, pricing, lead times or other needs please email or call us so one of our Design Consultants can offer personal assistance.

DO YOU SHIP INTERNATIONALLY?

We have successfully supplied tiles for projects all over the world. We are happy to provide a shipping quote for international orders.

CAN I GET SAMPLES?

Yes, we understand the importance of coordinating all the elements for your project and are happy to provide samples during your selection process.

Multiple samples can be ordered to give a sense of colour range. When you are ready to place an order you can also provide an approved colour control sample to the factory. Our team will use your sample as a guideline but please remember there will always be colour variation.

HOW SHOULD I DECIDE WHICH TYPE OF TILE TO USE?

The application environment and the traffic levels it will experience will determine the type of tile you should select. Please contact us and we will direct you to the product that best suits your needs.

ARE THERE ANY MINIMUM ORDER QUANTITIES? DO YOU CHARGE A SET-UP FEE FOR SMALLER ORDERS?

There is a 3 sqm minimum order per colour. Because each order is custom made, a set-up procedure is required.

SHOULD I ORDER EXTRA TILES?

Yes, we advise a 10% contingency on top of the minimum quantity needed. This overage allows for the possibility of breakage during installation, for greater range selection and extras in case of damage in the future. Always refer to your installer when determining quantities.

CAN I RETURN MY TILES?

Because we make our tile specially for you, returns are not accepted unless they are defective or damaged in shipping.

ONCE AN ORDER IS PLACED CAN I CHANGE IT?

Because each order is custom made, we cannot change it once it has gone into production. If you do have a change, please contact us immediately to see if we can help resolve the matter quickly.

WHAT WOULD BE THE MINIMUM LEAD TIME FOR EMERGENCY ORDERS?

If you need materials sooner for a rush order or job completion, please call and ask for a lead time specifically for you. Although we keep a limited quantity of our most popular products on hand, we operate on a first come first served policy without discrimination. When your order is placed check with us what is the estimated lead time.

■ PRODUCT UNDERSTANDING

IS CLAY A NATURAL MATERIAL?

Clay is a natural and biocompatible material that naturally embodies extraordinary thermal and structural performances.

WHY IS THE NOMINAL SIZE BIGGER THAN THE REAL?

Clay shrinks both during the drying process and the firing process. Tiles will shrink on average by 5% to 10% in size, depending on the clay type and by the firing time and temperature.

WHAT IS A BISQUE?

When you look at a glazed tile from the side you can see 2 layers. The body of the tile, or largest layer, is called the bisque. The top layer is called the glaze.

FREQUENTLY ASKED QUESTIONS

WHAT IS A CRAQUELÉ?

Some tiles are intentionally induced to craze to produce what is known as a craquelé finish. Craquelé glazed tiles should not be used on kitchen counter tops or surfaces subject to heavy uses.

WHY OXIDE EXPLOSIONS HAVE SUCH A VARIATION?

Oxide Explosions tiles vary in colour and surface quality due to variations in glaze thickness and temperature during the firing process. This natural variation is intrinsic to their beauty.

To avoid misconceptions, we require that all clients approve the full variation within each reference.

WHAT ARE SHEETED TILES?

The majority of our geometric designs can be divided into repeating components. These components are known as standard sheets. They fit together easily, requiring minimal or no tile cutting.

■ BESPOKE & CUSTOMISATION

CAN YOU REPRODUCE ANCIENT TILES?

Yes, we are quite well known for that. Please send us more information.

CAN I CUSTOMISE A PRODUCT?

Yes, we can customise tiles and objects to best fit your style.

CAN I USE MY OWN DESIGN?

Yes, you absolutely can. There are additional development charges and set-up fees applied to bespoke orders.

CAN I ORDER EDGE GLAZED TILES?

Yes, you can glaze edges. The edge selection you make will depend on your installation layout.





TERMS & CONDITIONS

New Terracotta products are available worldwide through showrooms, retailers and direct from us.

■ PLACING ORDERS

Please order carefully.

- Check the product specification. Samples may be requested.
- Check the quantities. Ordering proper quantities is essential, as we cannot guarantee an exact match between batches. We recommend ordering 10% extra tiles.
- Check delivery requirements and delivery costs.
- Once production has begun, orders cannot be cancelled.
- There is a 3 sqm minimum order per colour glaze.

■ PRICES

- Prices are subject to change without notice according to cost variations.
- All product prices quoted exclude the cost of delivery and taxes.
- VAT rate is 23%.

■ DELIVERY

- We can arrange delivery anywhere in the world. Please contact us to request a freight quote.
- Tiles are packed in cardboard boxes, loaded on a protected and sealed pallet. Pallets are delivered on the pavement.
- Special packing for bespoke products must be quoted. Please contact us.
- Freight quotes are passed on at cost with a 15€ pallet charge per pallet used.
- Delivery terms are to be considered indicative. Eventual delivery delays do not entitle customers to claim indemnity.

■ PAYMENT TERMS

- A 50% deposit is required to confirm your order.
- The balance is due before order released. The goods will be released immediately after the payment has been received and cleared in full.

■ LEAD TIMES

Nearly every New Terracotta product is made to order. Our lead times vary from product to product and may also be extended at certain times of the year. Nevertheless, we try to follow these timelines:

- In-stock tiles: 1 week to ship.
- Made to order tiles: 4 to 5 weeks to ship.
- Custom designed tiles and pottery: quoted on an individual basis.
- Exceptionally large quantities: quoted on an individual basis.

All lead times will be quoted on purchase order. Please contact us for stock checks.

■ TOLERANCE TO DIMENSIONS AND SHADES

- Tiles are referred to its nominal size, not its actual size. Due to the handcrafted nature of our products, dimensions are approximate and may be subject to a degree of inaccuracy.
- The number of tiles supplied per square meter is approximate and depends upon the suggested grout joint.
- A possible variation in shades is considered as a particularity of such products. Tiles may exhibit variations from samples and within a shipped lot.

TERMS & CONDITIONS

CUSTOM PROJECTS

Please inquire us about custom developments.

- Custom projects are priced accordingly.
- Custom sizes are available for an additional charge.
- Custom glazes are subject to Run of Kiln, which may be up to 10% over original quantity.

RETURNS

Please order carefully as we cannot accept returns.

Please check your products carefully on delivery.

- Any problems with quality, quantity and kind of material supplied must be reported to NEW TERRACOTTA within 7 working days of receipt of the order.
- In case of claim the buyer should put the disputed material at NEW TERRACOTTA ´s disposal for any defect checking. No claim will be accepted once the material has been installed.
- Damage caused by inappropriate installation, accident, misuse or improper maintenance is not covered by NEW TERRACOTTA products warranty.
- Variations in colour, shade, tonality, texture and crazing are inherent characteristics of NEW TERRACOTTA tiles and are not defects.
- Variations in facial dimensions and thickness will be allowed as per handcrafted products standards.
- Although NEW TERRACOTTA provides Installation and Maintenance guidelines, its liability is strictly limited to the supply of products.





Our client base is diverse and we work on projects big and small.

We are there for small studios and we collaborate with the super league of architecture.



LONGNECKS BAR

BONN, GERMANY

Field Tiles - Long 30 x 7 x 1,2 cm
in S001 Red Chili Pepper



CASA DO ESPINHADO

CASCAIS, PORTUGAL

Natural Cotto - Brick 24 x 4 x 2 cm
in N004 Terra Firing



RARE ARCHITECTURE

LONDRINO

LONDON, UNITED KINGDOM

Field Tiles - Square 14 x 14 x 1 cm
in After Lowry by Smink Things

photo by © Sebastian Böttcher



ALARQUITECTOS

CASA ACREDITAR

PORTO, PORTUGAL

Field Tiles - Square 14 x 14 x 1 cm
in Verde Acreditar

photo by @ João Morgado





PRIVATE RESIDENCE

MALVEIRA DA SERRA, PORTUGAL

Field Tiles - Square 10 x 10 x 1 cm

Field Tiles - Long 22 x 5 x 1,2 cm
in B029 Elephant Grey



ANAHORYALMEIDA

TASCA CHIC

LISBON, PORTUGAL

Field Tiles - Square 14 x 14 x 1 cm
Trims - V-Cap 14 x 5 x 1 cm
in S304 Du Vin Rouge

photo by @Rodrigo Cardoso

AL HABTOOR HILTON

DUBAI, UAE

Natural Cotto - Brick 24 x 5 x 2 cm
in N006 Terra Classic





STARBUCKS

JEWEL CHANGI AIRPORT, SINGAPORE

Field Tiles - Half Square 14 x 7 x 1 cm
in Special 9 Basic Colours

ANAHORYALMEIDA

JACARÉ

LISBON, PORTUGAL

Field Tiles - Square 14 x 14 x 1 cm
New Modern - Capitoné 14 x 14 x 1 cm
Trims - Cane 14 x 2,5 cm
in S391 Green Gaudi

photo by © Rodrigo Cardoso



ESTUDIO OLADE

BREMEN BAR

CANTABRIA, SPAIN

New Modern - Constellation 20 x 10,5 cm
in B088 Tempest Blue
in B042 Ice Grey White





TORO & LIAUTARD

LA PERRUCHE

PARIS, FRANCE

Natural Cotto - Brick 24 x 5 x 2 cm
in N004 Terra Firing

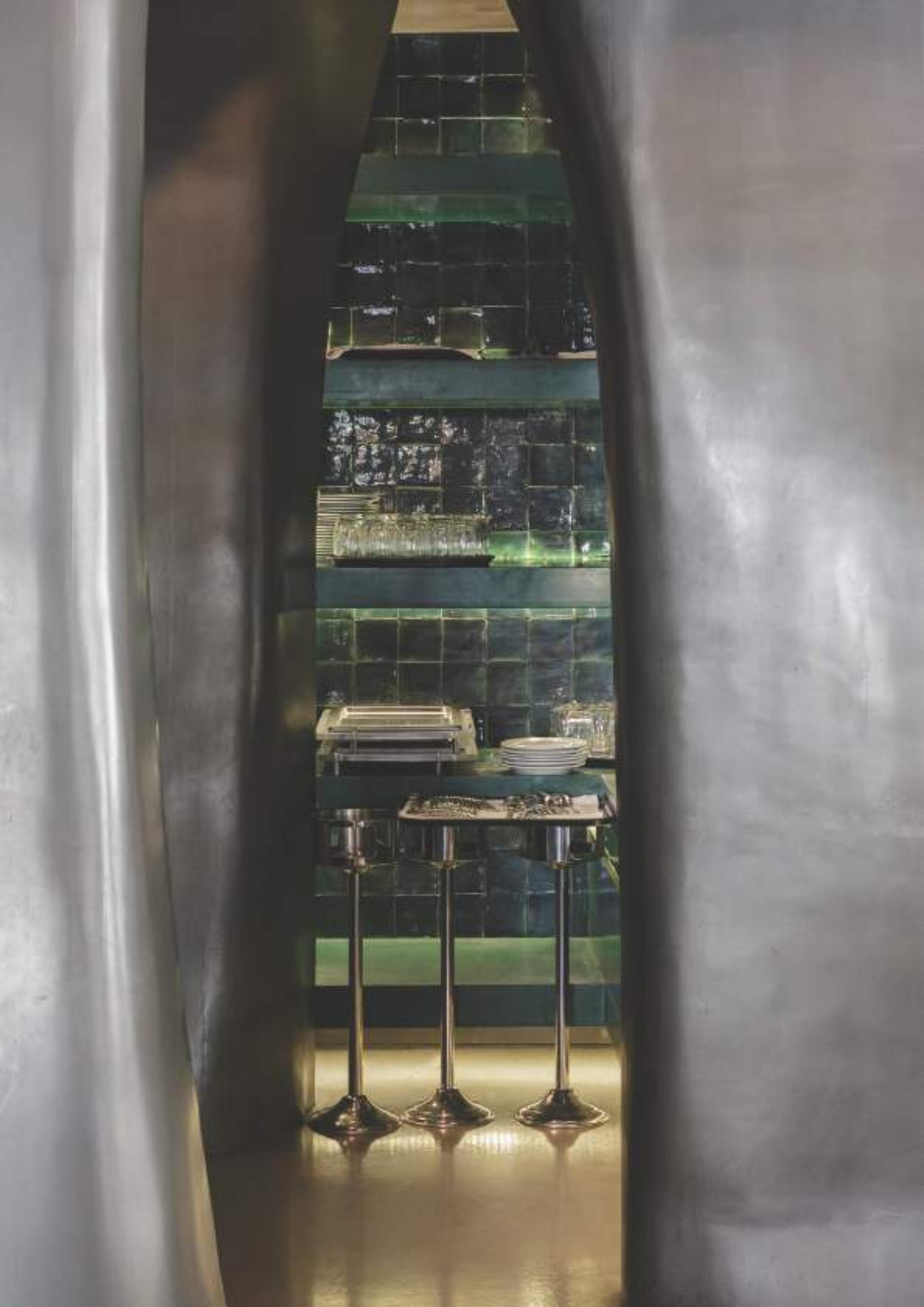

info@newterracotta.com

T. +351 214 681 626

M. +351 912 900 271 | +351 917 333 000

www.newterracotta.com

www.nwtmaterials.com

Polo Industrial Vale de Borregão,
3450-097 Marmeleira MRT
Portugal



Carta nº 123295

AZULEJARIA
CERÂMICA DE CONSTRUÇÃO

D.L. nº 110/2002, de 16 de Abril

PORTUGAL

Proud of being 100%
Handmade in Portugal

