

Cat

COL.

LEC.

TION

RES|GRES

RES: GRES



Pizarra	<b>14</b>
Lisa	<b>36</b>
Natural	<b>50</b>
Vento	<b>60</b>
Cosmo	<b>70</b>
Urban	<b>82</b>
Senda	<b>94</b>
Solid	<b>102</b>
Contract	<b>126</b>

Platos de ducha  
 Receveurs de douche  
 Shower trays  
 Piatti doccia

Encimeras para mueble  
 Plans de vasque pour meuble  
 Tops for bathroom cabinet  
 Top per mobili

PIZARRA

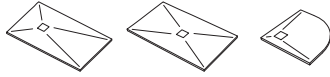

20

LISA

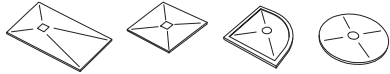

42

NATURAL

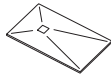

55

VENTO

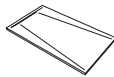

64

COSMO

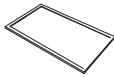

75

URBAN



88

SENDA

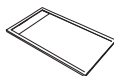

98

SOLID



106

CONTRACT

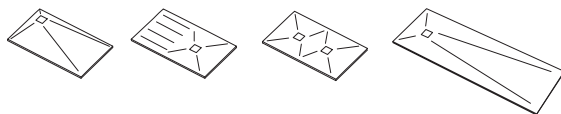

128



28

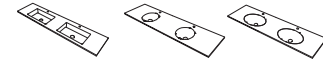

44



54

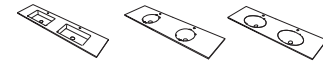

68



78

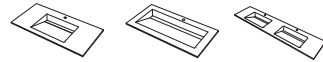

90



98



116

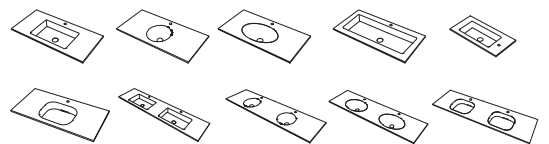

132

Encimeras suspendidas  
Plans de vasque suspendus  
Wall-hung tops  
Top sospesi

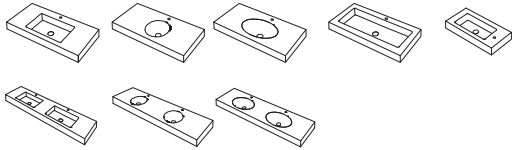

18

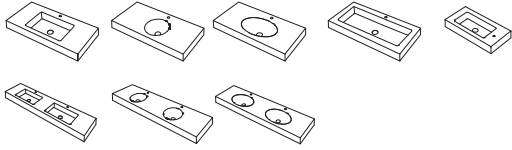

40

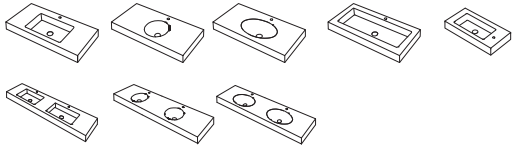

58

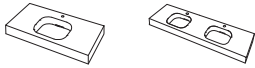

65

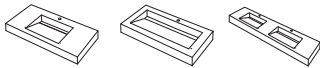

74

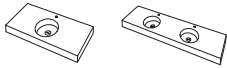

86

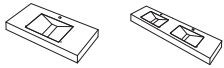

100

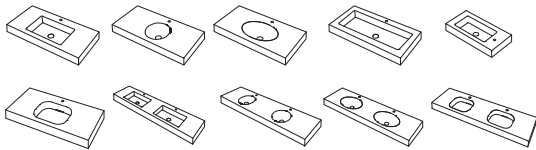

110

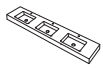

128

Lavabos  
Vasques  
Washbasins  
Lavabi

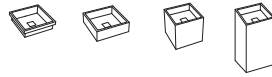

34

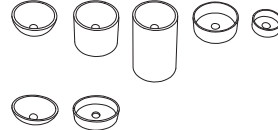

46



92

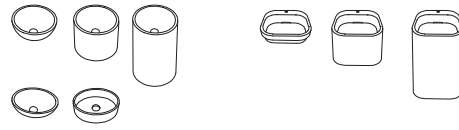

120

Bañeras  
Baignoires  
Bathtubs  
Vasche



111



INNOVATION  
SOLID SURFACE  
DESIGN

**Contract**  
Custom made  
Solid Surface

# Arte en cada pieza

Todas nuestras piezas tienen un ápice artesano, único. En nuestro sistema productivo aunamos procesos automatizados con procesos manuales, lo que hace que cada producto sea único y diferente al anterior. Una conjunción perfecta entre lo tradicional y lo moderno.

## **De l'art dans chaque pièce**

Toutes nos pièces ont une touche artisanale et unique car nous rassemblons les processus automatisés et manuels dans notre système de production ce qui rend chaque produit différent et unique. Une association parfaite entre tradition et modernité.

## **Art in every piece**

All our pieces are completely handmade and unique. Our pieces are created through a combination of automated and manual processes, making each product unique and different from the previous one. A seamless juxtaposition between tradition and modernity.

## **L'arte in ogni pezzo**

Tutti i nostri pezzi hanno un sapore artigianale, unico. Il nostro sistema di produzione abbina processi automatizzati con processi manuali, che rendono ogni prodotto unico nel suo genere e diverso dal precedente. Una perfetta coniugazione tra tradizionale moderno.







## El baño a medida, nuestra pasión

Una línea de producción flexible y sin límites permite adaptar nuestros productos tanto al espacio arquitectónico más sencillo como al diseño contract más exigente. Para nosotros, cualquier proyecto a medida es un nuevo reto al que no sabemos decir “no”.

### **La salle de bains sur mesure, notre passion**

Une ligne de production flexible et sans limites nous permet d’adapter nos produits aussi bien à l’espace architectural le plus simple comme au design Contract le plus exigeant. Pour nous, tout projet sur mesure est un nouveau défi que nous ne pouvons pas refuser.

### **A passion for custom-made bathrooms**

Our flexible and limit-less production line allows us to adapt our products to simple architectural spaces as well as rigorously demanding design contracts. For us, any made-to-measure project is an exciting challenge; ‘no’ is not in our vocabulary.

### **Il bagno su misura, la nostra passione**

Una linea di produzione flessibile e senza limiti ci consente di adattare i nostri prodotti sia allo spazio architettonico più semplice che alla progettazione contrattuale più complessa. Per noi, qualsiasi progetto su misura è una nuova sfida a cui non sappiamo dire “no”.

# La experiencia también importa

El 24 de julio de 2009, en un entorno con más de 30 años de experiencia en el sector del baño, nació nuestro primer plato de ducha extraplano de resina, uno de los primeros en comercializarse en Europa. El conocimiento y evolución de los materiales durante estos años nos ha permitido mejorar sus características, sus diseños así como complementarlo con lavabos, encimeras y diferentes accesorios de baño.

## L'expérience compte aussi

Le 24 juillet 2009, après plus de 30 ans d'expérience dans l'univers des salles de bains est né notre premier receveur extraplat en résine, l'un des premiers à être commercialisé en Europe. La connaissance et l'évolution des matériels pendant toutes ces années nous a permis d'améliorer leurs caractéristiques, leur design et de les compléter avec des lavabos, des plans de vasque et d'autres accessoires de bain.

## Experience is pivotal

On 24 July 2009, backed by over 30 years of experience in the bathroom sector, our first extra-flat resin shower tray was conceived, one of the first to be sold in Europe. Our expertise and the evolution of materials in recent years has allowed us to improve its features and design, while complementing it with washbasins, countertops and diverse bathroom accessories.

## Anche l'esperienza conta

Il 24 luglio 2009, da una realtà con oltre 30 anni di esperienza nel settore bagno, è nato il nostro primo piatto doccia in resina extrapiatto, uno dei primi commercializzati in Europa. La conoscenza e l'evoluzione dei materiali in questi anni ci ha permesso di migliorarne le caratteristiche e il design e di completarlo con lavabi, ripiani e diversi accessori da bagno.







# Seguimos nuestro camino, seguiremos innovando

El equipo Resigres lo forman mentes inquietas buscando siempre la excelencia en cada elaboración. Seguir nuestra propia ruta, con la innovación como compañera de viaje, nos ha permitido reinventar el baño ofreciendo diseños diferentes, nuevos sistemas de evacuación así como mejoras constantes en la calidad de nuestros materiales.

## **Nous poursuivons notre chemin vers l'innovation**

L'équipe de Resigres est formée par des esprits inquiets qui sont toujours à la recherche de l'excellence dans chacune de leurs collaborations. En suivant notre propre chemin en quête d'innovation, nous avons pu réinventer la salle de bains avec différentes propositions de designs, des nouveaux systèmes d'évacuation ainsi que des améliorations constantes en ce qui concerne la qualité de nos matériaux.

## **We are following our path, continuing to innovate**

The Resigres team is made up of curious minds, aiming for excellence in each production. Following our own path, innovating at every step of the way, has allowed us to reinvent the bathroom: we offer unique designs, new drainage systems and constantly improve on the quality of our materials.

## **Continuiamo il nostro percorso, continueremo ad innovare.**

Il team Resigres è composto da menti inquiete, sempre alla ricerca dell'eccellenza in ogni progetto. Andare avanti per la nostra strada, avendo l'innovazione per compagna di viaggio, ci ha permesso di reinventare il bagno offrendo design diversi, nuovi sistemi di evacuazione nonché costanti miglioramenti della qualità dei nostri materiali.



# PIZARRA

## Collection

La colección Pizarra se inspira en las texturas de una piedra, una roca densa de grano fino que desprende un aspecto rugoso dividido en finas lajas.

*La collection Pizarra s'inspire des textures d'une pierre, une roche compacte à grain fin qui fait ressortir un aspect rugueux divisé en fines plaques de pierre.*

*The Pizarra collection is inspired by the texture of this stone, a dense, fine-grained rock with a rugged appearance that is divided into fine slabs.*

*La collezione Pizarra si ispira alla texture di questa pietra, una roccia densa a grana fine che presenta un aspetto rugoso formato da tante lastre molto sottili.*











**ENCIMERA ATENEA PIZARRA**

Seno XL 120  
280 x 45 cm | h:14cm  
Color ártico

**BANDEJA**

Color ártico

**PLAN DE VASQUE ATENEA PIZARRA**

Vasque XL 120  
280 x 45 cm | h:14cm  
Coloris ártico

**PLATEAU**

Coloris ártico

**TOP ATENEA PIZARRA**

XL 120 integrated washbasin  
280 x 45 cm | h: 14 cm  
Colour ártico

**TRAY**

Colour ártico

**TOP ATENEA PIZARRA**

Lavabo XL 120 integrato  
280 x 45 cm | h: 14 cm  
Colore ártico

**VASSOJO**

Colore ártico



**PLATO DE DUCHA EXTRAPLANO PIZARRA**

Lateral 160 x 90 cm  
Color antracita  
Rejilla coloreada

**RECEVEUR DE DOUCHE EXTRAPLANO PIZARRA**

Latéral 160 x 90 cm  
Coloris antracita  
Grille colorée

**SHOWER TRAY EXTRAPLANO PIZARRA**

Lateral 160 x 90 cm  
Colour antracita  
Colored grid

**PIATTO DOCCIA EXTRAPLANO PIZARRA**

Laterale 160 x 90 cm  
Colore antracita  
Griglia colorata





**PLATO DE DUCHA EXTRAPLANO PIZARRA**

Lateral 140 x 90 cm

Color ártico

Rejilla coloreada

**PANEL PIZARRA**

2 x 240 x 70 cm | 240 x 90 cm

Color ártico

**ESTANTE PIZARRA**

30 x 12 cm

Color ártico

**RECEVEUR DE DOUCHE EXTRAPLANO PIZARRA**

Latéral 140 x 90 cm

Coloris ártico

Grille colorée

**PANNEAU PIZARRA**

2 x 240 x 70 cm | 240 x 90 cm

Coloris ártico

**ÉTAGÈRE PIZARRA**

30 x 12 cm

Coloris ártico

**SHOWER TRAY EXTRAPLANO PIZARRA**

Lateral 140 x 90 cm

Colour ártico

Colored grid

**PANEL PIZARRA**

2 x 240 x 70 cm | 240 x 90 cm

Colour ártico

**SHELF PIZARRA**

30 x 12 cm

Colour ártico

**PIATTO DOCCIA EXTRAPLANO PIZARRA**

Laterale 140 x 90 cm

Colore ártico

Griglia colorata

**PANNELLO PIZARRA**

2 x 240 x 70 cm | 240 x 90 cm

Colore ártico

**MENSOLA PIZARRA**

30 x 12 cm

Colore ártico

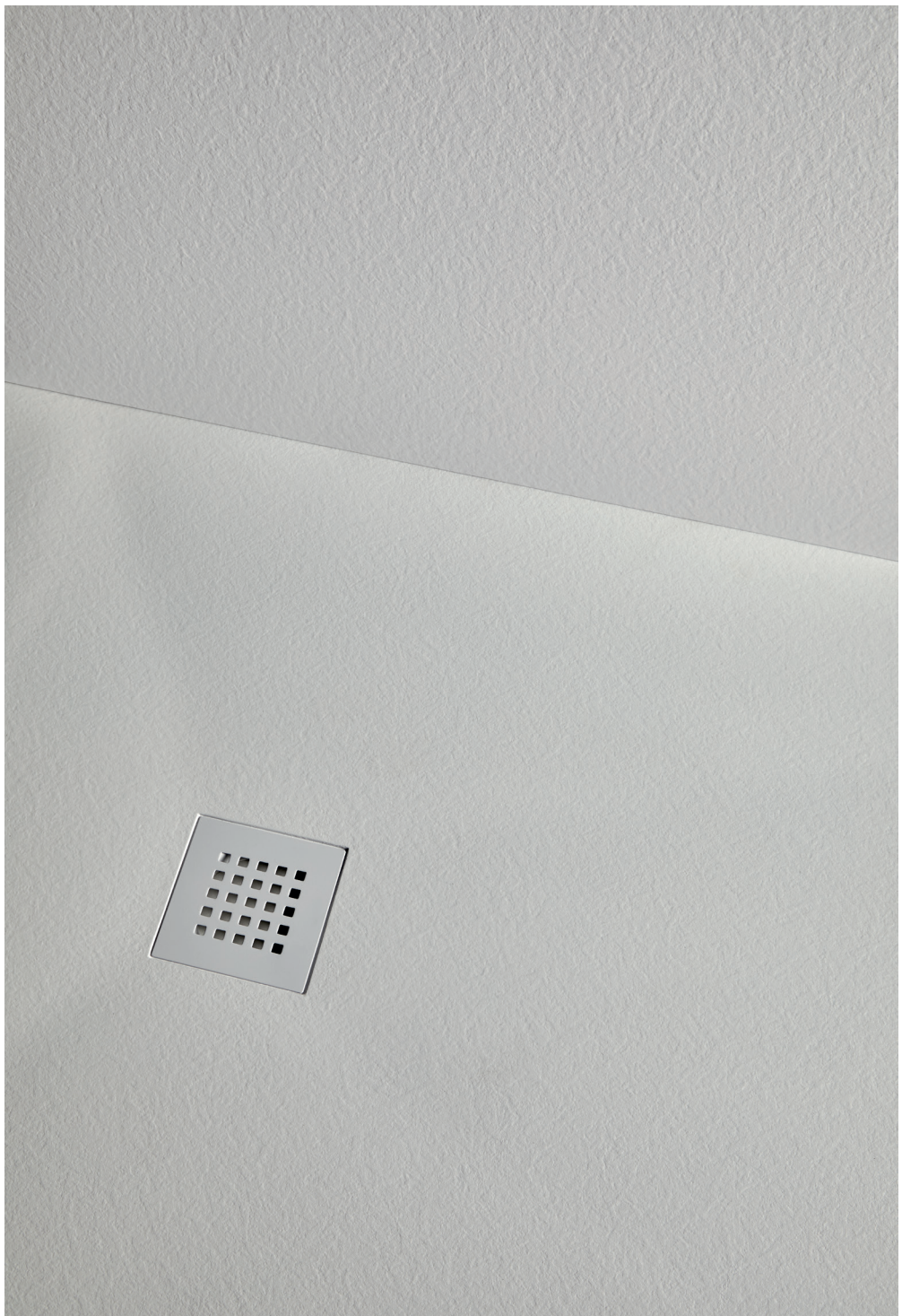





**ENCIMERA ATENEA PIZARRA**

Seno estándar  
100 x 45 cm | h: 14 cm  
Color antracita  
Válvula click coloreada

**PLAN DE VASQUE ATENEA PIZARRA**

Vasque estándar  
100 x 45 cm | h: 14 cm  
Coloris antracita  
Bonde click colorée

**TOP ATENEA PIZARRA**

Estándar integrated washbasin  
100 x 45 cm | h: 14 cm  
Colour antracita  
Colored click drain

**TOP ATENEA PIZARRA**

Lavabo estándar integrado  
100 x 45 cm | h: 14 cm  
Colore antracita  
Piletta click colorata



**ENCIMERA ATENEA PIZARRA**

Seno mini  
60 x 30 cm | h: 14 cm  
Color piedra  
Toallero mini  
Válvula click coloreada

**PLAN DE VASQUE ATENEA PIZARRA**

Vasque mini  
60 x 30 cm | h: 14 cm  
Coloris piedra  
Porte-serviette mini  
Bonde click colorée

**TOP ATENEA PIZARRA**

Mini integrated washbasin  
60 x 30 cm | h: 14 cm  
Colour piedra  
Towel rack mini  
Colored click drain

**TOP ATENEA PIZARRA**

Lavabo mini integrato  
60 x 30 cm | h: 14 cm  
Colore piedra  
Portasciugamani mini  
Piletta click colorata





**ENCIMERA SELENE PIZARRA**

Seno estándar  
121 x 46 cm  
Color ártico  
Válvula click coloreada

**PLAN DE VASQUE SELENE PIZARRA**

Vasque estándar  
121 x 46 cm  
Coloris ártico  
Bonde click colorée

**TOP SELENE PIZARRA**

Estándar integrated washbasin  
121 x 46 cm  
Colour ártico  
Colored click drain

**TOP SELENE PIZARRA**

Lavabo estándar integrato  
121 x 46 cm  
Colore ártico  
Piletta click colorata











**ENCIMERA SELENE PIZARRA**

Dos senos estándar  
161 x 46 cm  
Color antracita  
Válvula click coloreada

**PLAN DE VASQUE SELENE PIZARRA**

Double vasque estándar  
161 x 46 cm  
Coloris antracita  
Bonde click colorée

**TOP SELENE PIZARRA**

Double estándar integrated washbasin  
161 x 46 cm  
Colour antracita  
Colored click drain

**TOP SELENE PIZARRA**

Doppio lavabo estándar integrato  
161 x 46 cm  
Colore antracita  
Piletta click colorata



**LAVABO ARES PIZARRA**

H40

Color ártico

Tapa coloreada

**ENCIMERA GEA PIZARRA SF**

Espesor 3 cm

160 x 45 cm

Color piedra

**WASHBASIN ARES PIZARRA**

H40

Colour ártico

Colored cover

**TOP GEA PIZARRA SF**

Thickness 3 cm

160 x 45 cm

Colour piedra

**VASQUE ARES PIZARRA**

H40

Coloris ártico

Couvercle coloré

**TOP GEA PIZARRA SF**

Épaisseur 3 cm

160 x 45 cm

Coloris piedra

**LAVABO ARES PIZARRA**

H40

Colore ártico

Copri piletta colorata

**TOP GEA PIZARRA SF**

Spessore 3 cm

160 x 45 cm

Colore piedra





# LISA

Collection

Colección Lisa o la "no textura".  
*Collection Lisa ou la « non-texture ».*  
*The Lisa or 'untextured' collection.*  
*La collezione Lisa ovvero la "no texture".*







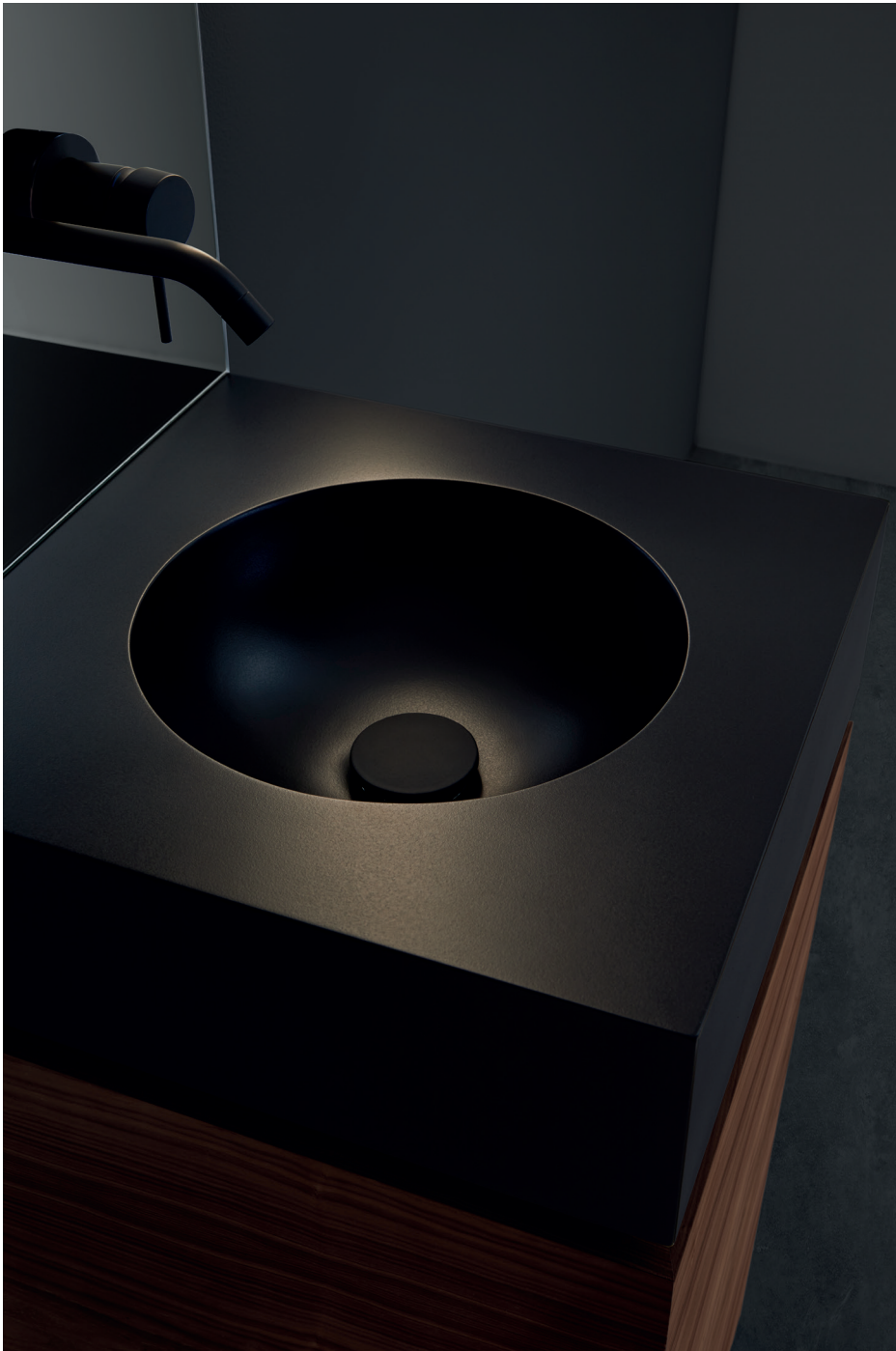

**ENCIMERA ATENEA LISA**

Seno circular  
45 x 45 cm | h: 14 cm  
Color negro  
Válvula click coloreada

**PLAN DE VASQUE ATENEA LISA**

Vasque circular  
45 x 45 cm | h: 14 cm  
Coloris negro  
Bonde click colorée

**TOP ATENEA LISA**

Circular integrated washbasin  
45 x 45 cm | h: 14 cm  
Colour negro  
Colored click drain

**TOP ATENEA LISA**

Lavabo circular integrato  
45 x 45 cm | h: 14 cm  
Colore negro  
Piletta click colorata



**PLATO DE DUCHA EXTRAPLANO LISO**

Central 100 x 100 cm  
Color ártico  
Rejilla coloreada  
Bordón 1 cm

**SHOWER TRAY EXTRAPLANO LISO**

Central 100 x 100 cm  
Colour ártico  
Colored grid  
Rim 1 cm

**RECEVEUR DE DOUCHE EXTRAPLANO LISO**

Central 100 x 100 cm  
Coloris ártico  
Grille colorée  
Rebord 1 cm

**PIATTO DOCCIA EXTRAPLANO LISO**

Centrale 100 x 100 cm  
Colore ártico  
Griglia colorata  
Bordo 1 cm





**ENCIMERA SELENE LISA**

Seno XL 85  
110 X 51 cm  
Color basalto  
Rebosadero  
Copete integrado curvo estándar H: 4 cm  
Válvula click coloreada

**PLAN DE VASQUE SELENE LISA**

Vasque XL 85  
110 X 51 cm  
Coloris basalto  
Trop plein  
Plinthe concave intégrée standard H: 4 cm  
Bonde click colorée

**TOP SELENE LISA**

XL 85 integrated washbasin  
110 X 51 cm  
Colour basalto  
Overflow  
Coved integrated standard backsplash H: 4 cm  
Colored click drain

**TOP SELENE LISA**

Lavabo XL 85 integrato  
110 X 51 cm  
Colore basalto  
Troppo pieno  
Alzatina integrata arrotondata standard H: 4 cm  
Piletta click colorata







**LAVABO NEO**  
Recto  
Color ártico  
Válvula click coloreada  
**ENCIMERA GEA LISA SF**  
Espesor 2 cm  
120 x 46 | 10 x 46 | 60 x 46 cm  
Color ártico

**VASQUE NEO**  
Recto  
Coloris ártico  
Bonde click colorée  
**TOP GEA LISA SF**  
Épaisseur 2 cm  
120 x 46 | 10 x 46 | 60 x 46 cm  
Coloris ártico

**WASHBASIN NEO**  
Recto  
Coluor ártico  
Colored click drain  
**TOP GEA LISA SF**  
Thickness 2 cm  
120 x 46 | 10 x 46 | 60 x 46 cm  
Coluor ártico

**LAVABO NEO**  
Recto  
Colore ártico  
Piletta click colorata  
**TOP GEA LISA SF**  
Spessore 2 cm  
120 x 46 | 10 x 46 | 60 x 46 cm  
Colore ártico







**LAVABO CRONO**

H90  
Color gris 7015  
Bandeja lateral  
Válvula click coloreada

**VASQUE TOTEM CRONO**

H90  
Coloris gris 7015  
Plateau latéral  
Bonde click colorée

**WASHBASIN CRONO**

H90  
Colour gris 7015  
Lateral tray  
Colored click drain

**LAVABO CRONO**

H90  
Colore gris 7015  
Mensole laterale  
Piletta click colorata





# NATURAL

Collection

La colección Natural se inspira en una suave, fina y regular textura que evoca a diversos elementos presentes en la naturaleza.

*La collection Natural d'une texture douce, fine et régulière évoque divers éléments présents dans la nature.*

*This Natural collection is inspired by a soft, fine and smooth texture that evokes various elements present in nature.*

*La collezione Natural si ispira ad una texture morbida, fine e regolare che evoca i vari elementi presenti in natura.*







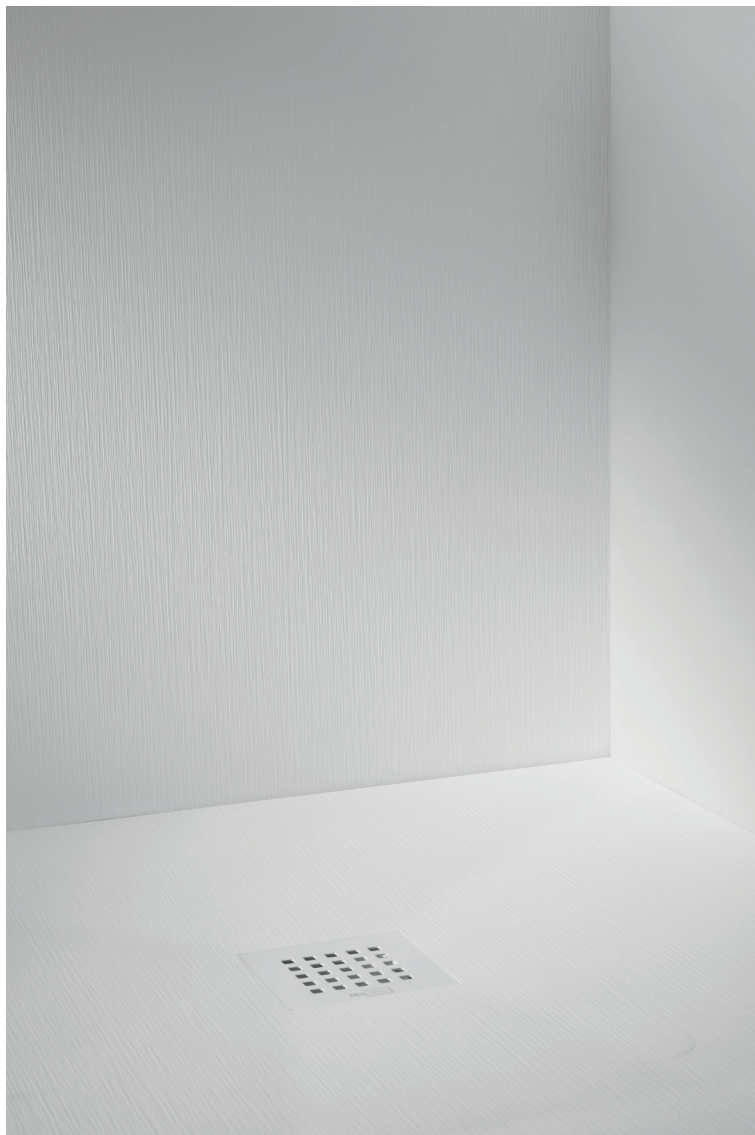

**PLATO DE DUCHA EXTRAPLANO NATURAL**

Lateral 160 X 80 cm

Color ártico

**PANEL NATURAL**

200 X 80 cm | 200 x 160 cm

Color ártico

**ENCIMERA SELENE NATURAL**

Seno estándar

140 X 51 cm

Color ártico

Válvula click coloreada

**SHOWER TRAY EXTRAPLANO NATURAL**

Lateral 160 X 80 cm

Colour ártico

**PANEL NATURAL**

200 X 80 cm | 200 x 160 cm

Colour ártico

**TOP SELENE NATURAL**

Estándar integrated washbasin

140 X 51 cm

Colour ártico

Colored click drain

**RECEVEUR DE DOUCHE EXTRAPLANO NATURAL**

Latéral 160 X 80 cm

Coloris ártico

**PANNEAU NATURAL**

200 X 80 cm | 200 x 160 cm

Coloris ártico

**PLAN DE VASQUE SELENE NATURAL**

Vasque estándar

140 X 51 cm

Coloris ártico

Bonde click colorée

**PIATTO DOCCIA EXTRAPLANO NATURAL**

Laterale 160 X 80 cm

Colore ártico

**PANNELLO NATURAL**

200 X 80 cm | 200 x 160 cm

Colore ártico

**TOP SELENE NATURAL**

Lavabo estándar integrado

140 X 51 cm

Colore ártico

Piletta click colorata



**ENCIMERA SELENE NATURAL**

Seno mini  
60 X 31 cm  
Color antracita  
Válvula click coloreada

**TOP SELENE NATURAL**

Mini integrated washbasin  
60 X 31 cm  
Colour antracita  
Colored click drain

**PLAN DE VASQUE SELENE NATURAL**

Vasque mini  
60 X 31 cm  
Coloris antracita  
Bonde click colorée

**TOP SELENE NATURAL**

Lavabo mini integrato  
60 X 31 cm  
Colore antracita  
Piletta click colorata







**ENCIMERA ATENEA NATURAL**

Dos senos oval  
150 X 46 cm | h: 14 cm  
Color gris 7015  
Copete a medida H: 25 cm  
Válvula click coloreada

**PLAN DE VASQUE ATENEA NATURAL**

Double vasque oval  
150 X 46 cm | h: 14 cm  
Coloris gris 7015  
Plinthe sur mesure H: 25 cm  
Bonde click colorée

**TOP ATENEA NATURAL**

Double oval integrated washbasin  
150 X 46 cm | h: 14 cm  
Colour gris 7015  
Custom backsplash H: 25 cm  
Colored click drain

**TOP ATENEA NATURAL**

Doppio lavabo oval integrato  
150 X 46 cm | h: 14 cm  
Colore gris 7015  
Alzatina su misura H: 25 cm  
Piletta click colorata





# VENTO

Collection

Vento, emerge de la necesidad de encontrar elementos que expresen lo esencial y eliminen lo superfluo.

*La collection Vento nait du besoin de trouver des éléments qui expriment l'essentiel et éliminent le superflu.*

*The Vento collection addresses the quest to find elements that express minimalism and eliminate what is superfluous.*

*Vento, scaturisce dall'esigenza di trovare elementi che esprimano l'essenziale ed eliminino il superfluo.*











**PLATO DE DUCHA VENTO**

180 X 80 cm  
Color antracita  
**ENCIMERA VENTO CF**  
Dos senos vento 60  
180 X 50 cm | h: 14 cm  
Textura pizarra | Color antracita

**RECEVEUR DE DOUCHE VENTO**

180 X 80 cm  
Coloris antracita  
**PLAN DE VASQUE VENTO CF**  
Double vasque vento 60  
180 X 50 cm | h: 14 cm  
Finition pizarra | Coloris antracita

**SHOWER TRAY VENTO**

180 X 80 cm  
Colour antracita  
**TOP VENTO CF**  
Double vento 60 integrated washbasin  
180 X 50 cm | h: 14 cm  
Finish pizarra | Colour antracit

**PIATTO DOCCIA VENTO**

180 X 80 cm  
Colore antracita  
**TOP VENTO CF**  
Doppio lavabo vento 60 integrato  
180 X 50 cm | h: 14 cm  
Finitura pizarra | Colore antracita



**PLATO DE DUCHA VENTO**  
120 x 80 cm  
Color ártico

**SHOWER TRAY VENTO**  
120 x 80 cm  
Colour ártico

**RECEVEUR DE DOUCHE VENTO**  
120 x 80 cm  
Coloris ártico

**PIATTO DOCCIA VENTO**  
120 x 80 cm  
Colore ártico



**ENCIMERA VENTO SF**  
Dos senos vento 40  
151 X 46 cm  
Textura lisa | Color piedra

**TOP VENTO SF**  
Double vento 40 integrated washbasin  
151 X 46 cm  
Finish lisa | Colour piedra

**PLAN DE VASQUE VENTO SF**  
Double vasque vento 40  
151 X 46 cm  
Finition lisa | Coloris piedra

**TOP VENTO SF**  
Doppio lavabo vento 40 integrato  
151 X 46 cm  
Finitura lisa | Colore piedra







Collection  
**COSMO**

La colección Cosmo, invisible, elementos formados por líneas rectas en orden y armonía buscando mimetizarse con el entorno.

*La collection Cosmo, invisible, rassemble des éléments formés par des lignes droites en ordre et en harmonie avec leur milieu.*

*The Cosmo collection is inconspicuous, its elements formed by straight lines that emulate an order and harmony that blend in with the environment.*

*La collezione Cosmo, invisibile, con elementi formati da linee rette ordinate e armoniose che cercano di mimetizzarsi con l'ambiente.*











**PLATO DE DUCHA COSMO**

170 X 90 cm

Color ártico

**ENCIMERA COSMO CF**

Seno cosmo estándar

65 X 45 cm | h: 14 cm

Color ártico

**RECEVEUR DE DOUCHE COSMO**

170 X 90 cm

Coloris ártico

**PLAN DE VASQUE COSMO CF**

Vasque cosmo standard

65 X 45 cm | h: 14 cm

Coloris ártico

**SHOWER TRAY COSMO**

170 X 90 cm

Colour ártico

**TOP COSMO CF**

Standard cosmo integrated washbasin

65 X 45 cm | h: 14 cm

Colour ártico

**PIATTO DOCCIA COSMO**

170 X 90 cm

Colore ártico

**TOP COSMO CF**

Lavabo cosmo standard integrato

65 X 45 cm | h: 14 cm

Colore ártico



**PLATO DE DUCHA COSMO**  
160 x 90 cm  
Color antracita

**SHOWER TRAY COSMO**  
160 x 90 cm  
Colour antracita

**RECEVEUR DE DOUCHE COSMO**  
160 x 90 cm  
Coloris antracita

**PIATTO DOCCIA COSMO**  
160 x 90 cm  
Colore antracita

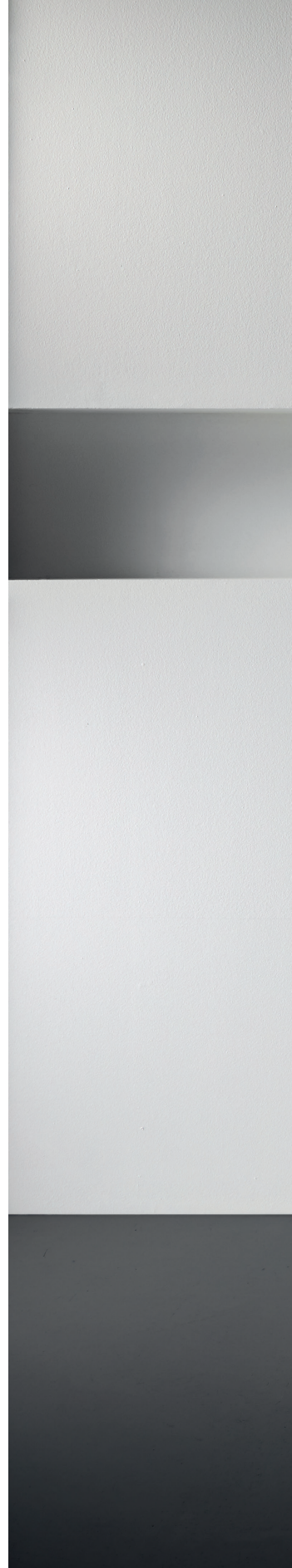





**ENCIMERA COSMO SF**

Seno cosmo XL 85  
121 X 51 cm  
Color gris 7015  
Extensión con toallero estándar

**PLAN DE VASQUE COSMO SF**

Vasque cosmo XL 85  
121 X 51 cm  
Coloris gris 7015  
Extension avec porte-serviette standard

**TOP COSMO SF**

Cosmo XL 85 integrated washbasin  
121 X 51 cm  
Colour gris 7015  
Extension with standard towel rack

**TOP COSMO SF**

Lavabo cosmo XL 85 integrato  
121 X 51 cm  
Colore gris 7015  
Estensione con portasciugamani standard





**ENCIMERA COSMO CF**  
Seno cosmo XL 120  
160 X 46 cm  
Color piedra

**PLAN DE VASQUE COSMO CF**  
Vasque cosmo XL 120  
160 X 46 cm  
Coloris piedra

**TOP COSMO CF**  
Cosmo XL 120 integrated washbasin  
160 X 46 cm  
Colour piedra

**TOP COSMO CF**  
Lavabo cosmo XL 120 integrato  
160 X 46 cm  
Colore piedra



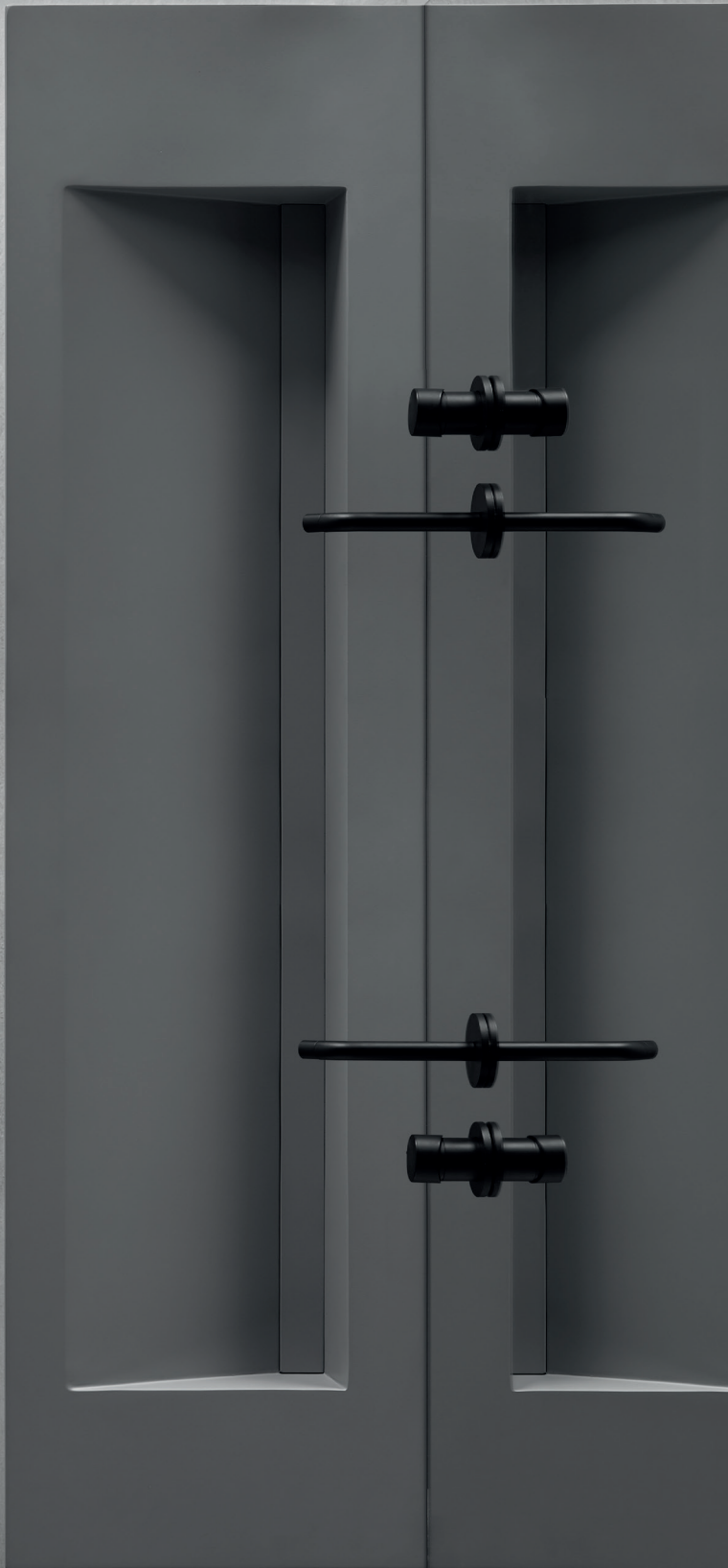



# URBAN

Collection

Colección Urban, inspirada en las nuevas tendencias, conectando cualquier punto a un núcleo central fino y elegante.

*La collection Urban s'inspire des nouvelles tendances en raccordant n'importe quel point à un noyau central fin et élégant.*

*The Urban collection, inspired by new trends, delicate and elegant at its very core.*

*Collezione Urban, ispirata alle nuove tendenze, collega qualsiasi punto ad un nucleo centrale fine ed elegante.*









**ENCIMERA URBAN CF**

Dos senos  
180 X 50 cm | h: 14 cm  
Color ártico

**PLAN DE VASQUE URBAN CF**

Double vasque  
180 X 50 cm | h: 14 cm  
Coloris ártico

**TOP URBAN CF**

Double washbasin integrated  
180 X 50 cm | h: 14 cm  
Colour ártico

**TOP URBAN CF**

Doppio lavabo integrato  
180 X 50 cm | h: 14 cm  
Colore ártico



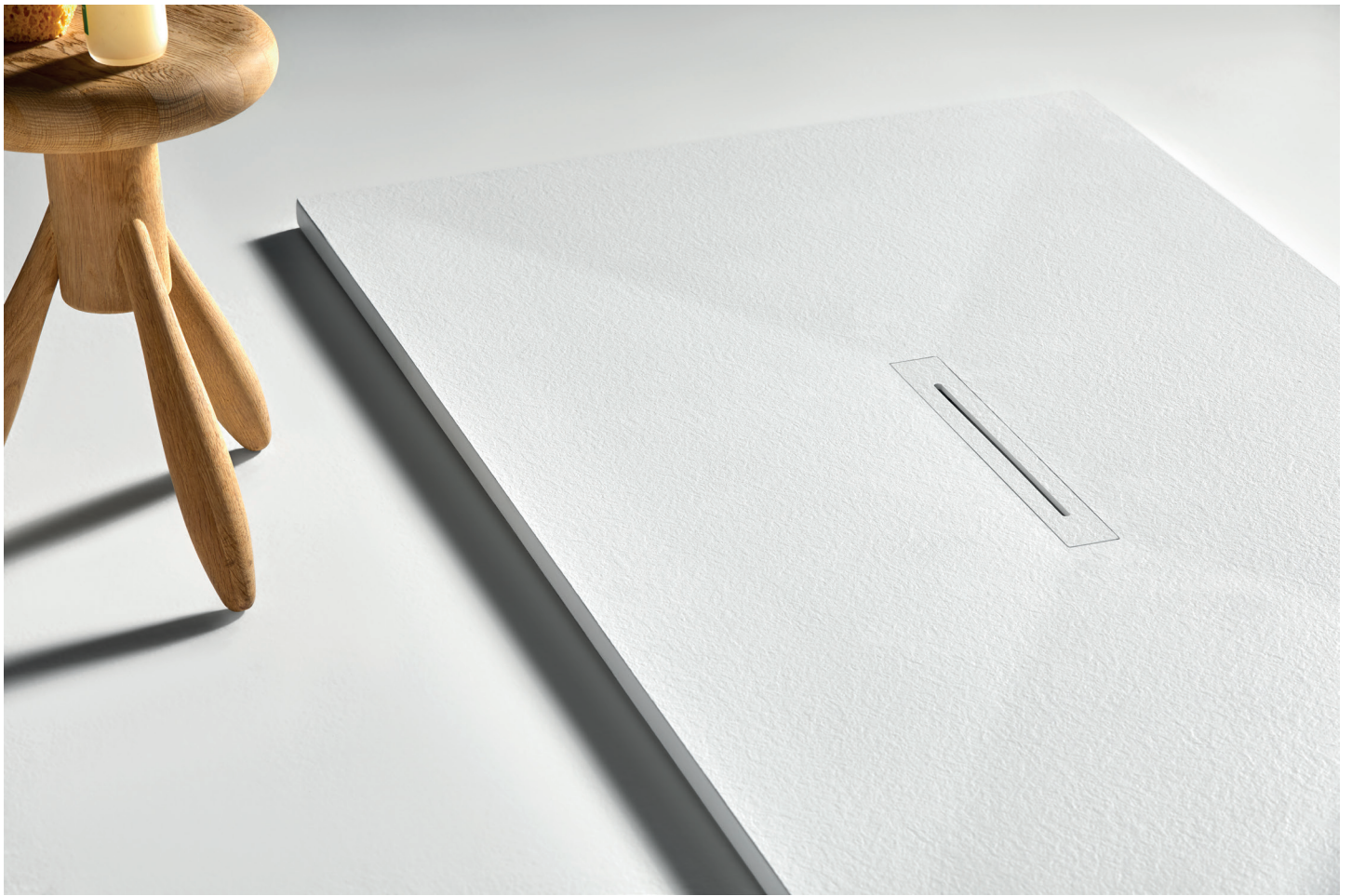

**PLATO DE DUCHA URBAN**  
180 x 90 cm  
Color ártico

**SHOWER TRAY URBAN**  
180 x 90 cm  
Colour ártico

**RECEVEUR DE DOUCHE URBAN**  
180 x 90 cm  
Coloris ártico

**PIATTO DOCCIA URBAN**  
180 x 90 cm  
Colore ártico

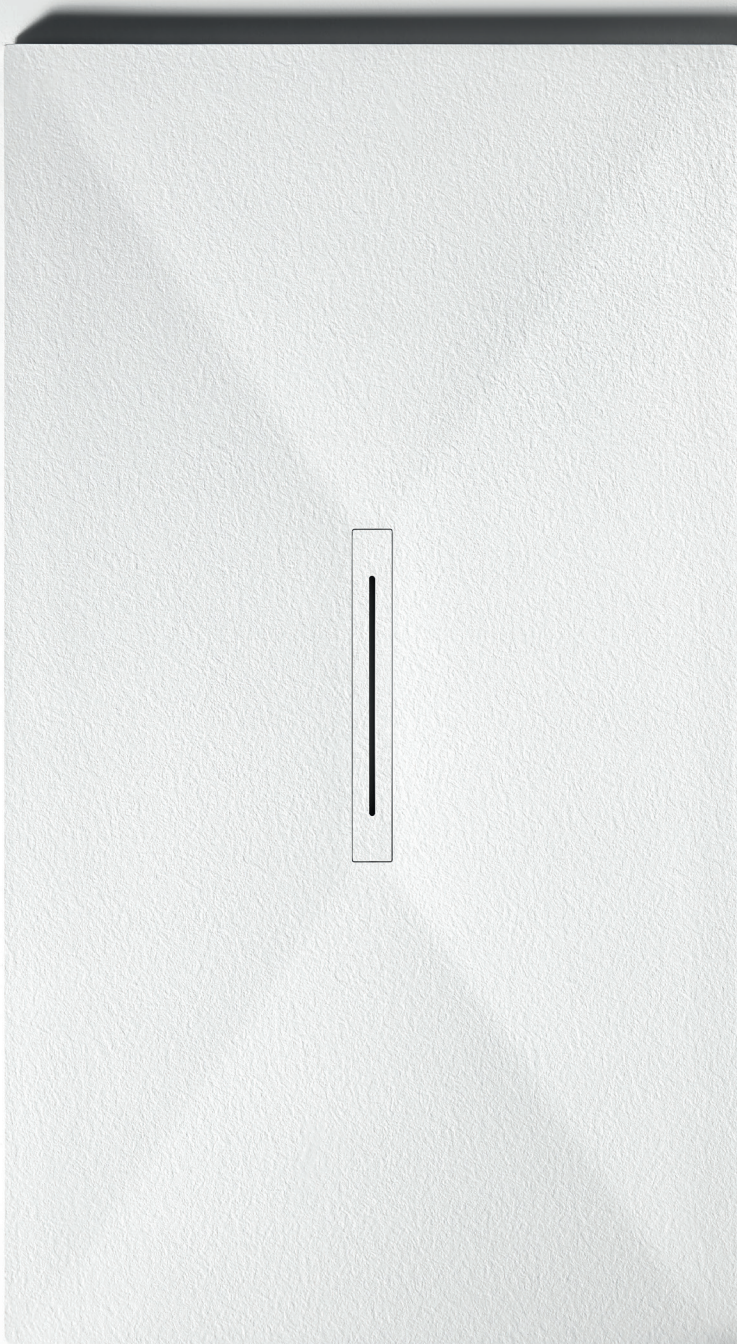

**ENCIMERA URBAN SF**

Un seno  
100 X 47 cm  
Color antracita  
Corte curvo a medida

**PLAN DE VASQUE URBAN SF**

Une vasque  
100 X 47 cm  
Coloris antracita  
Découpe en courbe sur mesure

**TOP URBAN SF**

Single integrated washbasin  
100 X 47 cm  
Colour antracita  
Custom curved cut

**TOP URBAN SF**

Un lavabo integrato  
100 X 47 cm  
Colore antracita  
Taglio curvo su misura







**LAVABO URBAN**  
Color negro  
**ENCIMERA GEA PIZARRA SF**  
Espesor 2 cm  
181 x 46 cm  
Color negro

**VASQUE URBAN**  
Coloris negro  
**TOP GEA PIZARRA SF**  
Épaisseur 2 cm  
181 x 46 cm  
Coloris negro

**WASHBASIN URBAN**  
Colour negro  
**TOP GEA PIZARRA SF**  
Thickness 2 cm  
181 x 46 cm  
Colour negro

**LAVABO URBAN**  
Colore negro  
**TOP GEA PIZARRA SF**  
Spessore 2 cm  
181 x 46 cm  
Colore negro





# SENDA

Collection

Colección Senda, historia viva del conjunto que sigue mostrando el itinerario más sencillo hacia cada parte.

*La collection Senda, histoire vivante de l'ensemble montre toujours la voie la plus simple vers chaque partie.*

*The Senda collection, inspired by stories that illustrate the simplest path to a destination.*

*Collezione Senda, storia viva di un insieme che continua mostrando l'itinerario più semplice verso ogni parte.*









**PLATO DE DUCHA SENDA**

160 X 80 cm

Color piedra

**ENCIMERA SENDA SF**

Dos senos

151 X 46 cm

Color piedra

**PANEL LISO**

220 X 80

Color piedra

Hornacina integrada

**SHOWER TRAY SENDA**

160 X 80 cm

Colour piedra

**TOP SENDA SF**

Double integrated washbasin

151 X 46 cm

Colour piedra

**PANEL LISO**

220 X 80

Colour piedra

Integrated shower niche

**RECEVEUR DE DOUCHE SENDA**

160 X 80 cm

Coloris piedra

**PLAN DE VASQUE SENDA SF**

Double vasque

151 X 46 cm

Coloris piedra

**PANNEAU LISO**

220 X 80

Coloris piedra

Niche intégrée

**PIATTO DOCCIA SENDA**

160 X 80 cm

Colore piedra

**TOP SENDA SF**

Doppio lavabo integrato

151 X 46 cm

Colore piedra

**PANNELLO LISO**

220 X 80

Colore piedra

Mensola integrata



**ENCIMERA SENDA CF**

Un seno  
100 X 46 cm | h: 14 cm  
Color moka  
Copete integrado recto H: 30 cm  
Toallero estándar 35x3,5

**PLAN DE VASQUE SENDA CF**

Une vasque  
100 X 46 cm | h: 14 cm  
Coloris moka  
Plinthe intégrée à angle droit H: 30 cm  
Porte-serviette standard 35x3,5

**TOP SENDA CF**

Single integrated washbasin  
100 X 46 cm | h: 14 cm  
Colour moka  
90 degree backsplash integrated H: 30 cm  
Standard 35x3,5 towel rack

**TOP SENDA CF**

Un lavabo integrato  
100 X 46 cm | h: 14 cm  
Colore moka  
Alzatina integrata ad angolo retto H: 30 cm  
Portasciugamani standard 35x3,5





Collection  
**SOLID**

Suavidad, calidez, comodidad, pureza y luminosidad se funden en un solo material.

*Douceur, chaleur, confort, pureté et luminosité se fondent dans un unique matériau.*

*Softness, warmth, comfort, purity and radiance merge into one single material.*

*Morbidezza, calore, comfort, purezza e luminosità si fondono in un unico materiale.*







PLATO HYDRA FRONTAL  
120 X 80 cm  
Solid surface S-bianco

SHOWER TRAY HYDRA FRONTAL  
120 X 80 cm  
Solid surface S-bianco

RECEVEUR DE DOUCHE HYDRA FRONTAL  
120 X 80 cm  
Solid surface S-bianco

PIATTO DOCCIA HYDRA FRONTAL  
120 X 80 cm  
Solid surface S-bianco





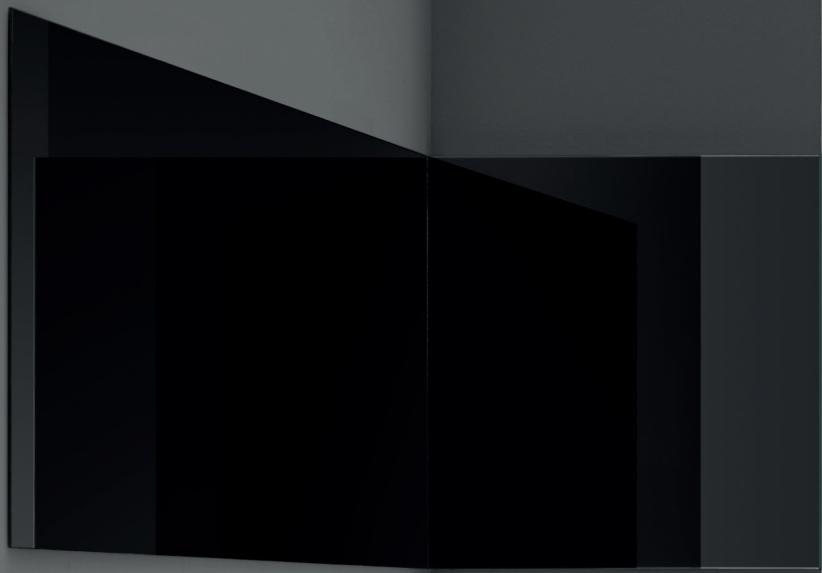







**BAÑERA HYDRA**

170 X 80 cm  
Solid surface S-blanco

**BANDEJA**

Solid surface S-blanco  
**ENCIMERA OLIMPIA CF**

Dos senos olimpia 40  
160 X 46 cm | h: 14 cm  
Solid surface S-blanco  
Copete integrado curvo H: 14 cm

**BAIGNOIRE HYDRA**

170 X 80 cm  
Solid surface S-blanco

**PLATEAU**

Solid surface S-blanco  
**PLAN DE VASQUE OLIMPIA CF**  
Double vasque olimpia 40  
160 X 46 cm | h: 14 cm  
Solid surface S-blanco  
Plinthe intégrée concave H: 14 cm

**BATHTUB HYDRA**

170 X 80 cm  
Solid surface S-blanco

**TRAY**

Solid surface S-blanco  
**TOP OLIMPIA CF**  
Double olimpia 40 integrated washbasin  
160 X 46 cm | h: 14 cm  
Solid surface S-blanco  
Coved integrated backsplash H: 14 cm

**VASCA HYDRA**

170 X 80 cm  
Solid surface S-blanco

**VASSOIO**

Solid surface S-blanco  
**TOP OLIMPIA CF**  
Doppio lavabo olimpia 40 integrato  
160 X 46 cm | h: 14 cm  
Solid surface S-blanco  
Alzatina integrata arrotondata H: 14 cm





**PLATO HYDRA CENTRAL**

160 X 80 cm  
Solid surface S-bianco

**SHOWER TRAY HYDRA CENTRAL**

160 X 80 cm  
Solid surface S-bianco

**RECEVEUR DE DOUCHE HYDRA CENTRAL**

160 X 80 cm  
Solid surface S-bianco

**PIATTO DOCCIA HYDRA CENTRAL**

160 X 80 cm  
Solid surface S-bianco



**PLATO DILOS**  
120 X 80 cm  
Solid surface S-blanco  
Tapa solid surface

**SHOWER TRAY DILOS**  
120 X 80 cm  
Solid surface S-blanco  
Solid surface cover

**RECEVEUR DE DOUCHE DILOS**  
120 X 80 cm  
Solid surface S-blanco  
Couvercle solid surface

**PIATTO DOCCIA DILOS**  
120 X 80 cm  
Solid surface S-blanco  
Coperchio solid surface







**ENCIMERA HYDRA**

Seno XL 120  
181 X 51 cm  
Solid surface S-blanco  
Válvula click solid surface

**PLAN DE VASQUE HYDRA**

Vasque XL 120  
181 X 51 cm  
Solid surface S-blanco  
Bonde click solid surface

**TOP HYDRA**

XL 120 integrated washbasin  
181 X 51 cm  
Solid surface S-blanco  
Solid surface click drain

**TOP HYDRA**

Lavabo XL 120 integrato  
181 X 51 cm  
Solid surface S-blanco  
Piletta click solid surface



**ENCIMERA BARI**

Seno estándar  
120 X 45 cm | h: 14 cm  
Solid surface S-blanco  
Válvula click solid surface  
**ENCIMERA RODAS CF**  
140 X 45 cm | h: 6 cm  
Solid surface S-blanco

**PLAN DE VASQUE BARI**

Vasque estándar  
120 X 45 cm | h: 14 cm  
Solid surface S-blanco  
Bonde click solid surface  
**TOP RODAS CF**  
140 X 45 cm | h: 6 cm  
Solid surface S-blanco

**TOP BARI**

Estándar integrated washbasin  
120 X 45 cm | h: 14 cm  
Solid surface S-blanco  
Solid surface click drain  
**TOP RODAS CF**  
140 X 45 cm | h: 6 cm  
Solid surface S-blanco

**TOP BARI**

Lavabo estándar integrado  
120 X 45 cm | h: 14 cm  
Solid surface S-blanco  
Piletta click solid surface  
**TOP RODAS CF**  
140 X 45 cm | h: 6 cm  
Solid surface S-blanco







**LAVABO LOTTO**

H40  
Solid surface S-bianco  
Válvula click solid surface  
**ENCIMERA RODAS SF**  
Espesor 2 cm  
81 x 51 cm  
Solid surface S-bianco

**VASQUE LOTTO**

H40  
Solid surface S-bianco  
Bonde click solid surface  
**PLAN DE TRAVAIL RODAS SF**  
Épaisseur 2 cm  
81 x 51 cm  
Solid surface S-bianco

**WASHBASIN LOTTO**

H40  
Solid surface S-bianco  
Solid surface click drain  
**TOP RODAS SF**  
Thickness 2 cm  
81 x 51 cm  
Solid surface S-bianco

**LAVABO LOTTO**

H40  
Solid surface S-bianco  
Piletta solid surface  
**TOP RODAS SF**  
Spessore 2 cm  
81 x 51 cm  
Solid surface S-bianco





**LAVABO OLIMPIA**  
H90  
Solid surface S-blanco  
Con bandeja lateral

**WASHBASIN OLIMPIA**  
H90  
Solid surface S-blanco  
With lateral tray

**VASQUE TOTEM OLIMPIA**  
H90  
Solid surface S-blanco  
Avec plateau latéral

**LAVABO OLIMPIA**  
H90  
Solid surface S-blanco  
Con mensola laterale



**BAÑERA HYDRA**  
170 X 80 cm  
Solid surface S-blanco

**BATHTUB HYDRA**  
170 X 80 cm  
Solid surface S-blanco

**BAIGNOIRE HYDRA**  
170 X 80 cm  
Solid surface S-blanco

**VASCA HYDRA**  
170 X 80 cm  
Solid surface S-blanco







Collection  
**CONTRACT**

La versatilidad de los elementos en su máxima expresión.

*La versatilité des éléments dans leur expression ultime.*

*A true expression of the versatility of the elements.*

*La versatilità degli elementi nella loro massima espressione.*





**PLATO DE DUCHA LISO MECANIZADO**

280x90

Color ártico

Tres desagües

Ranura para mampara

**ENCIMERA CONTRACT SOLID CF**

3 lavabos termoformados a medida

240X50 | h: 25 cm

Solid surface S-blanco

**SHOWER TRAY LISO MACHINING**

280x90

Colour ártico

Three drains

Groove for enclosures

**TOP CONTRACT SOLID CF**

3 custom thermoformed washbasins

240X50 | h: 25 cm

Solid surface S-blanco

**RECEVEUR DE DOUCHE LISO MÉCANISÉ**

280x90

Coloris ártico

Trois écoulements

Rainure pour parois de douche

**PLAN DE VASQUE CONTRACT SOLID CF**

3 vasques thermoformées sur mesure

240X50 | h: 25 cm

Solid surface S-blanco

**PIATTO DOCCIA LISO MECCANIZZATO**

280x90

Colore ártico

Tre scarichi

Scanalatura per box doccia

**TOP CONTRACT SOLID CF**

3 lavabi termoformati su misura

240X50 | h: 25 cm

Solid surface S-blanco





**PLATO DE DUCHA COSMO MECANIZADO**  
280x90 cm  
Color negro  
Dos desagües

**RECEVEUR DE DOUCHE COSMO MÉCANISÉ**  
280x90 cm  
Coloris negro  
Deux écoulements

**SHOWER TRAY COSMO MACHINING**  
280x90 cm  
Colour negro  
Two drains

**PIATTO DOCCIA COSMO MECCANIZZATO**  
280x90 cm  
Colore negro  
Due scarichi







ENCIMERA CONTRACT SOLID SF  
340x51 cm  
Solid surface S-blanco  
Mecanizado a medida  
LAVABO OLIMPIA  
H40

TOP CONTRACT SOLID SF  
340x51 cm  
Solid surface S-blanco  
Trous sur mesure  
VASQUE OLIMPIA  
H40

TOP CONTRACT SOLID SF  
340x51 cm  
Solid surface S-blanco  
Custom hole  
WASHBASIN OLIMPIA  
H40

TOP CONTRACT SOLID SF  
340x51 cm  
Solid surface S-blanco  
Foro su misura  
VASQUE OLIMPIA  
H40

ENCIMERA CONTRACT LISA CF

3 senos estándar  
46X300 | h: 40-12  
Color RAL 7021

TOP CONTRACT LISA CF

3 estándar integrated washbasins  
46X300 | h: 40-12  
Colour RAL 7021

PLAN DE VASQUE CONTRACT LISA CF

3 vasques estándar  
46X300 | h: 40-12  
Coloris RAL 7021

TOP CONTRACT LISA CF

3 lavabi estándar integrati  
46X300 | h: 40-12  
Colore RAL 7021









**TECH**

## EXTRAPLANO PIZARRA

Lateral | Latéral | Lateral | Laterale

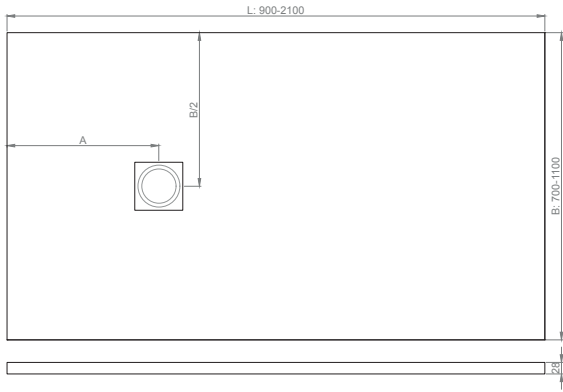

	A (mm)				
	B:700	B:800	B:900	B:1000	B:1100
L:900	350	350	-	-	-
L:1000	400	400	400	-	-
L:1100	350	350	350	350	-
L:1200	400	400	400	400	400
L:1300	350	350	350	350	350
L:1400	400	400	400	400	400
L:1500	350	350	450	450	450
L:1600	400	400	500	500	500
L:1700	350	350	500	500	500
L:1800	400	400	550	550	550
L:1900	500	500	500	500	500
L:2000	550	550	550	550	550
L:2100	-	600	600	600	600

Central | Central | Central | Centrale

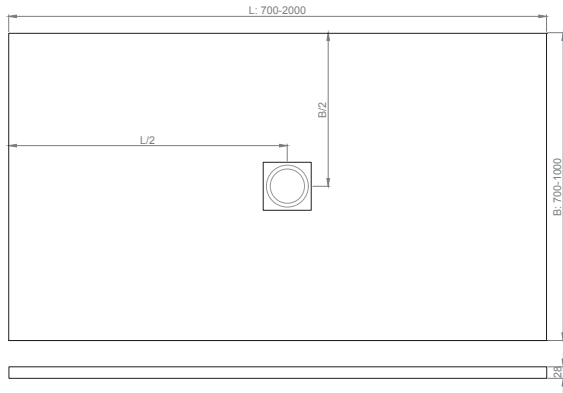

Semicircular | 1/4 round | Corner | Semicircolare

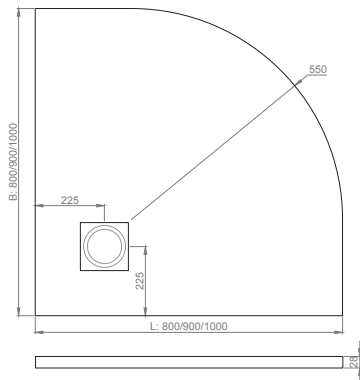

Válvulas | Bonde | Drain | Sifone

Estandar 0,65/s, Atornillada, Sujeción inox  
0,65/s, Vissée, Fixation inox  
0,65/s, Screwed, Fixing inox  
0,65/s, Avvitato, Anello inox

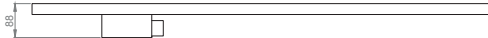

Geberit 0,50/s, Atornillada, Sujeción inox  
0,50/s, Vissée, Fixation inox  
0,50/s, Screwed, Fixing inox  
0,50/s, Avvitato, Anello inox

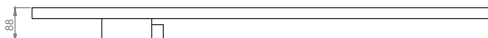

Vertical 0,80/s, Atornillada, Sujeción inox  
0,80/s, Vissée, Fixation inox  
0,80/s, Screwed, Fixing inox  
0,80/s, Avvitato, Anello inox

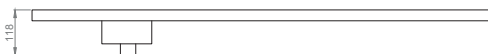

Rejilla | Grille | Grid | Griglia

Inox AISI 316



Lateral | Latéral | Lateral | Laterale

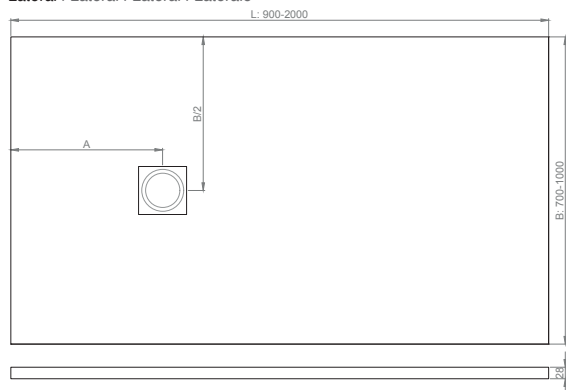

	A (mm)			
	B:700	B:800	B:900	B:1000
L:900	350	350	-	-
L:1000	400	400	400	-
L:1100	350	350	350	350
L:1200	400	400	400	400
L:1300	350	350	350	350
L:1400	400	400	400	400
L:1500	350	350	450	450
L:1600	400	400	500	500
L:1700	350	350	500	500
L:1800	400	400	550	550
L:1900	500	500	500	500
L:2000	550	550	550	550

Central | Central | Central | Centrale

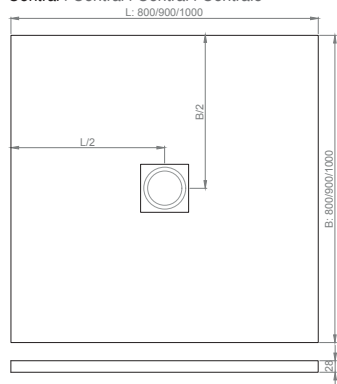

Circular | Circulaire | Circular | Circolare

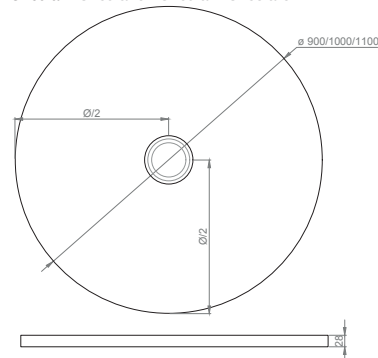

Semicircular | 1/4 round | Corner | Semicircolare

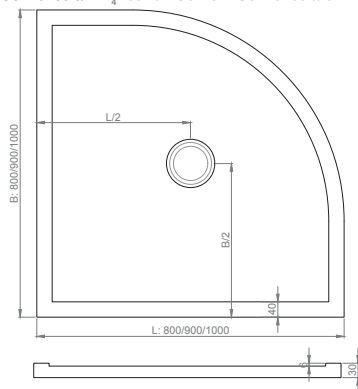

Válvulas | Bonde | Drain | Sifone

Estandar 0,65l/s, Atornillada, Sujeción inox  
0,65l/s, Vissée, Fixation inox  
0,65l/s, Screwed, Fixing inox  
0,65l/s, Avvitato, Anello inox



Geberit 0,50l/s, Atornillada, Sujeción inox  
0,50l/s, Vissée, Fixation inox  
0,50l/s, Screwed, Fixing inox  
0,50l/s, Avvitato, Anello inox



Vertical 0,80l/s, Atornillada, Sujeción inox  
0,80l/s, Vissée, Fixation inox  
0,80l/s, Screwed, Fixing inox  
0,80l/s, Avvitato, Anello inox

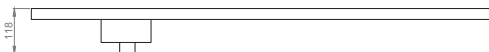

Rejilla | Grille | Grid | Griglia

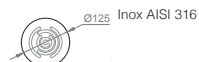
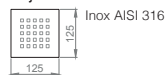

## EXTRAPLANO NATURAL

Lateral | Latéral | Lateral | Laterale

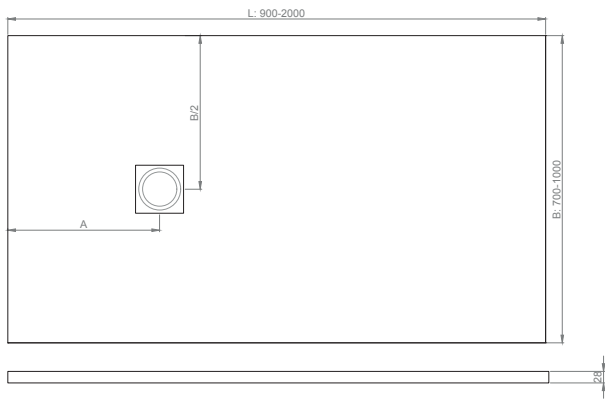

	A (mm)			
	B:700	B:800	B:900	B:1000
L:900	350	350	-	-
L:1000	400	400	400	-
L:1100	350	350	350	350
L:1200	400	400	400	400
L:1300	350	350	350	350
L:1400	400	400	400	400
L:1500	350	350	450	450
L:1600	400	400	500	500
L:1700	350	350	500	500
L:1800	400	400	550	550
L:1900	500	500	500	500
L:2000	550	550	550	550

## Válvulas | Bonde | Drain | Sifone

**Estandar** 0,65/s, Atornillada, Sujeción inox  
 0,65/s, Vissée, Fixation inox  
 0,65/s, Screwed, Fixing inox  
 0,65/s, Avvitato, Anello inox

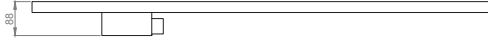

**Geberit** 0,50/s, Atornillada, Sujeción inox  
 0,50/s, Vissée, Fixation inox  
 0,50/s, Screwed, Fixing inox  
 0,50/s, Avvitato, Anello inox

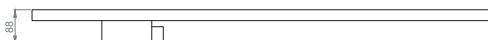

**Vertical** 0,80/s, Atornillada, Sujeción inox  
 0,80/s, Vissée, Fixation inox  
 0,80/s, Screwed, Fixing inox  
 0,80/s, Avvitato, Anello inox

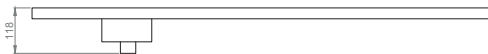

## Rejilla | Grille | Grid | Griglia

Inox AISI 316



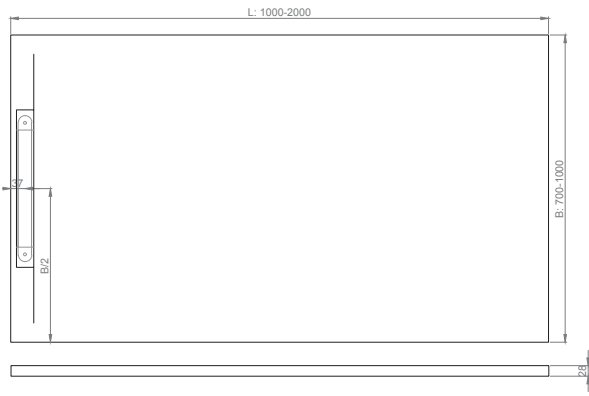

Válvulas | Bonde | Drain | Sifone

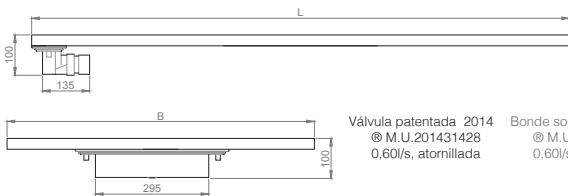

Válvula patentada 2014  
© M.U.201431428  
0,60l/s, atornillada

Bonde sous licence 2014  
© M.U.201431428  
0,60l/s, vissée

Patented drain 2014  
© M.U.201431428  
0,60l/s, screwed

Sifone brevettato 2014  
© M.U.201431428  
0,60l/s, avvitato

Tapa | Couvercle | Top | Copertura

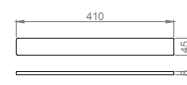

Masa interna no coloreada  
Masse interne non colorée  
Internal mass not colored  
Massa interna non colorata

**COSMO**

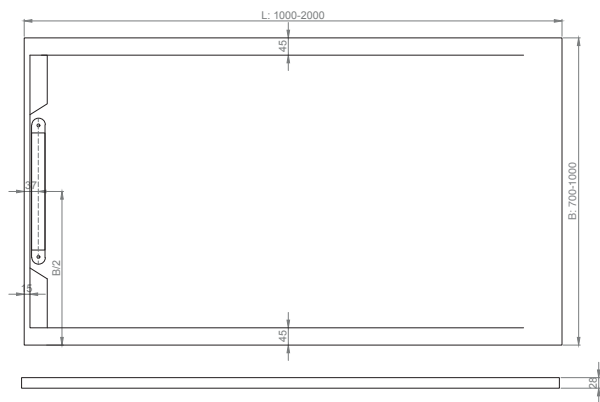

**Válvulas | Bonde | Drain | Sifone**

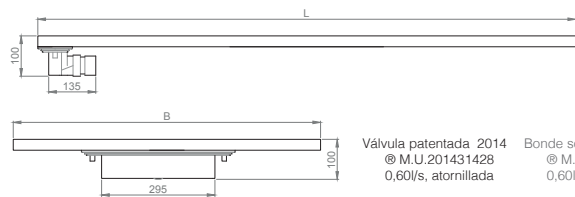

Válvula patentada 2014  
© M.U.201431428  
0,60l/s, atornillada

Bonde sous licence 2014  
© M.U.201431428  
0,60l/s, vissée

Patented drain 2014  
© M.U.201431428  
0,60l/s, screwed

Sifone brevettato 2014  
© M.U.201431428  
0,60l/s, avvitato

**Tapa | Couvercle | Top | Copertura**

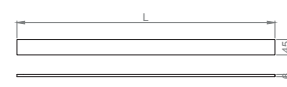

Masa interna no coloreada  
Masse interne non colorée  
Internal mass not colored  
Massa interna non colorata

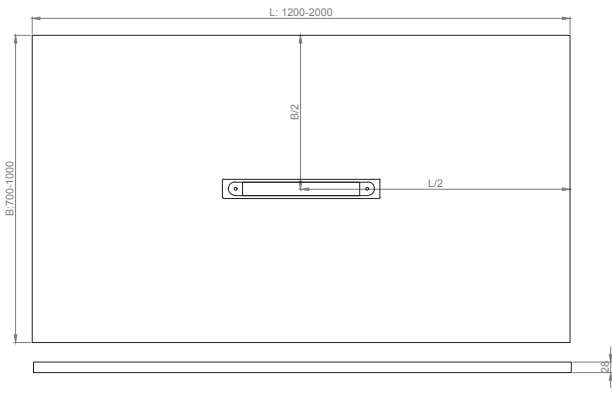

Válvulas | Bonde | Drain | Sifone

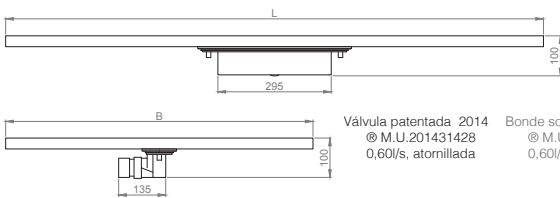

Válvula patentada 2014  
© M.U.201431428  
0,60l/s, atornillada

Bonde sous licence 2014  
© M.U.201431428  
0,60l/s, vissée

Patented drain 2014  
© M.U.201431428  
0,60l/s, screwed

Sifone brevettato 2014  
© M.U.201431428  
0,60l/s, avvitato

Tapa | Couvercle | Top | Copertura

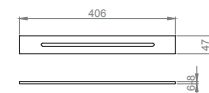

Masa interna no coloreada  
Masse interne non colorée  
Internal mass not colored  
Massa interna non colorata



**SENDA**

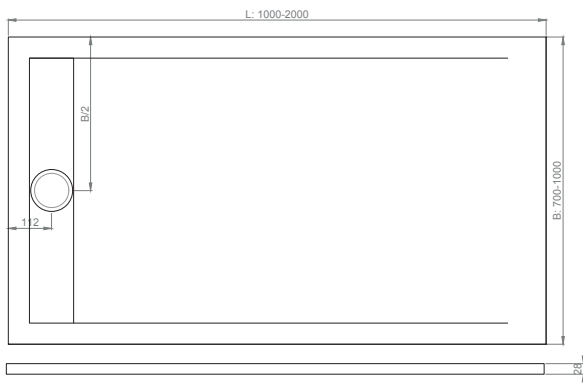

**Válvulas | Bonde | Drain | Sifone**

**Estandar** 0,65Vs, Atornillada, Sujeción inox  
 0,65Vs, Vissée, Fixation inox  
 0,65Vs, Screwed, Fixing inox  
 0,65Vs, Avvitato, Anello inox

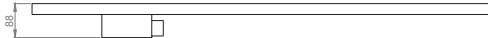

**Geberit** 0,50Vs, Atornillada, Sujeción inox  
 0,50Vs, Vissée, Fixation inox  
 0,50Vs, Screwed, Fixing inox  
 0,50Vs, Avvitato, Anello inox

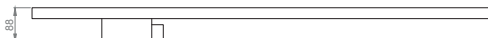

**Vertical** 0,80Vs, Atornillada, Sujeción inox  
 0,80Vs, Vissée, Fixation inox  
 0,80Vs, Screwed, Fixing inox  
 0,80Vs, Avvitato, Anello inox

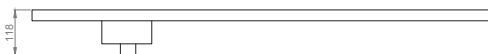

**Rejilla | Grille | Grid | Griglia**



Inox AISI 316

Lateral | Latéral | Lateral | Laterale

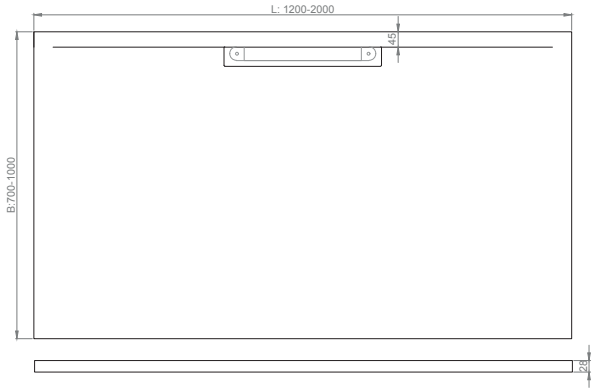

Tapa | Couvercle | Top | Copertura

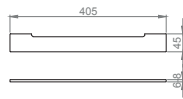

Masa interna no coloreada  
 Masse interne non colorée  
 Internal mass not colored  
 Massa interna non colorata

Central | Central | Central | Centrale

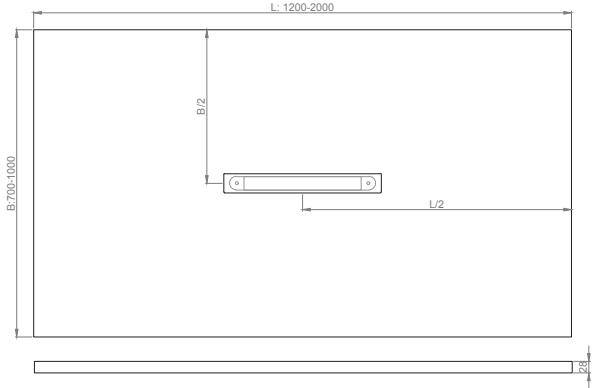

Tapa | Couvercle | Top | Copertura

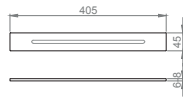

Masa interna no coloreada  
 Masse interne non colorée  
 Internal mass not colored  
 Massa interna non colorata

Válvulas | Bonde | Drain | Sifone

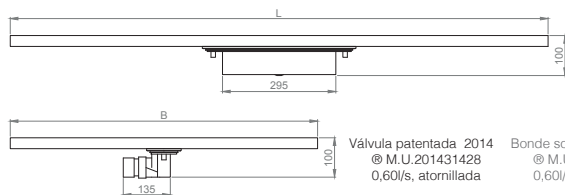

Válvula patentada 2014  
 © M.U.201431428  
 0,60l/s, atornillada

Bonde sous licence 2014  
 © M.U.201431428  
 0,60l/s, vissée

Patented drain 2014  
 © M.U.201431428  
 0,60l/s, screwed

Sifone brevettato 2014  
 © M.U.201431428  
 0,60l/s, avvitato

# DILOS

## Lateral | Latéral | Lateral | Laterale

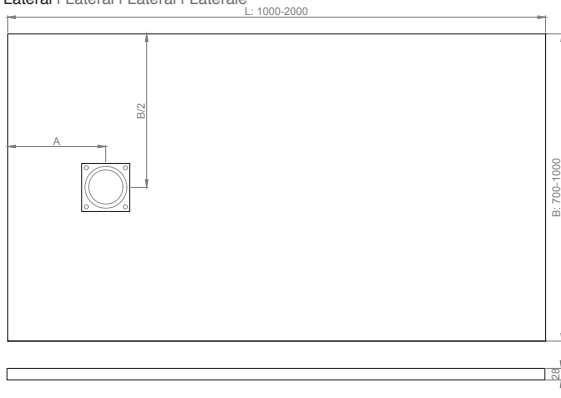

	A (mm)			
	B:700	B:800	B:900	B:1000
L:1000	250	250	250	-
L:1100	250	250	250	250
L:1200	250	250	250	250
L:1300	250	250	250	250
L:1400	250	250	250	250
L:1500	250	250	250	250
L:1600	250	250	250	250
L:1700	300	300	300	300
L:1800	300	300	300	300
L:1900	300	300	300	300
L:2000	300	300	300	300

## Central | Central | Central | Centrale

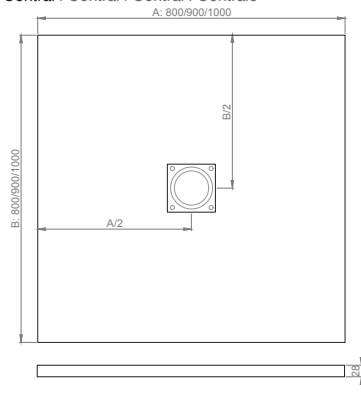

## Válvulas | Bonde | Drain | Sifone

**Estandar** 0,65l/s, Atornillada, Sujeción inox  
 0,65l/s, Vissée, Fixation inox  
 0,65l/s, Screwed, Fixing inox  
 0,65l/s, Avvitato, Anello inox



**Geberit** 0,50l/s, Atornillada, Sujeción inox  
 0,50l/s, Vissée, Fixation inox  
 0,50l/s, Screwed, Fixing inox  
 0,50l/s, Avvitato, Anello inox

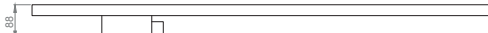

**Vertical** 0,80l/s, Atornillada, Sujeción inox  
 0,80l/s, Vissée, Fixation inox  
 0,80l/s, Screwed, Fixing inox  
 0,80l/s, Avvitato, Anello inox



## Rejilla | Grille | Grid | Griglia

Inox AISI 316



Solid surface



La velocidad de desagüe puede disminuir hasta un 30% con respecto a la rejilla inox  
 La velocidad de desagüe puede disminuir hasta un 30% con respecto a la rejilla inox  
 La velocidad de desagüe puede disminuir hasta un 30% con respecto a la rejilla inox  
 La velocidad de desagüe puede disminuir hasta un 30% con respecto a la rejilla inox

Ranura para mampara | Rainure pour parois de douche | Groove for enclosures | Scanalatura per box doccia

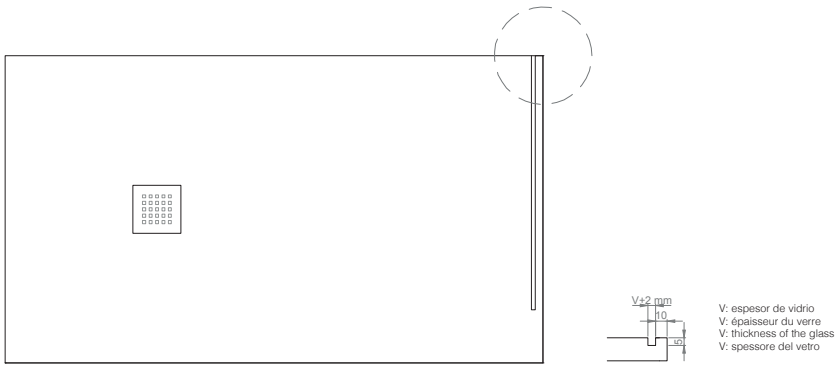

Bordón a medida | Rebord sur mesure | Custom rim | Bordo su misura

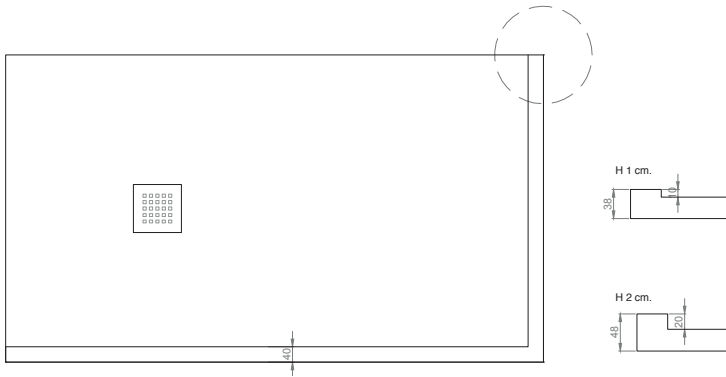

Cortes a medida | Découpes sur mesure | Cut to size | Tagli su misura

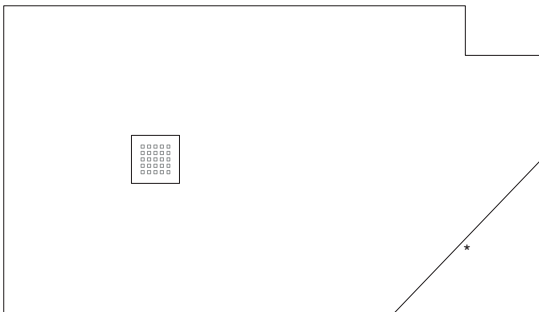

\* Los cortes inclinados no son compatibles con el apoyo de mamparas. Solo recomendable si el lado va contra pared.

\* Les coupes obliques sont incompatibles avec l'appui des parreaux de douches. Conseillé seulement si le côté va contre le mur.

\* Sloping lines are not compatible with shower screen supports. Only recommended when the side touches the wall.

\* I tagli inclinati non sono compatibili con il supporto delle pareti della doccia. Consigliato solo se il lato va contro la parete.

# ATENEA | BARI

## SENO ESTÁNDAR | VASQUE ESTÁNDAR | WASHBASIN ESTÁNDAR | LAVABO ESTÁNDAR

Dimensiones seno | Vasque dimensions | Washbasin dimensions | Dimensioni lavabo

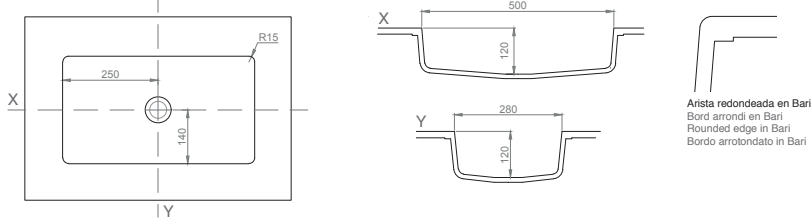

Rebosadero | Trop plein | Overflow | Troppo pieno

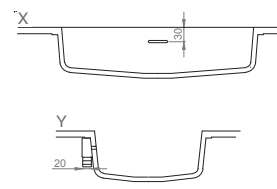

Arista redondeada en Bari  
Bord arrondi en Bari  
Rounded edge in Bari  
Bordo arrotondato in Bari

## Configuraciones estándar | Configurations standard | Standard configurations | Configurazione standard

Un seno | Une vasque | Single integrated washbasin | Un lavabo integrato

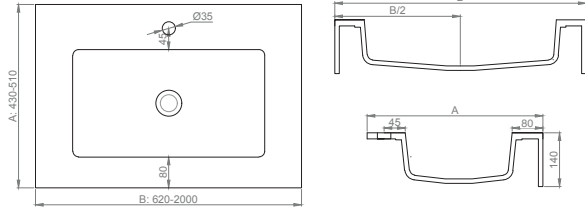

Dos senos | Double vasque | Double integrated washbasin | Doppio lavabo integrato

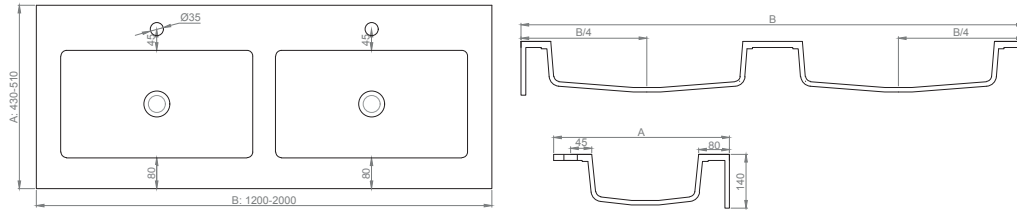

## Distancias mínimas | Distances minimales | Minimum distances | Distanze minime

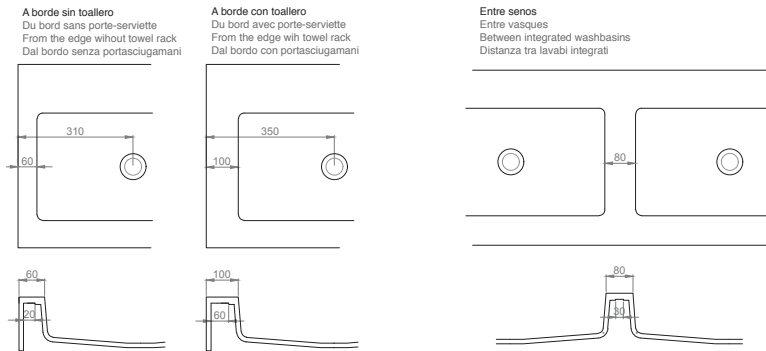

## Tamaños mínimos | Dimensions minimales | Minimum sizes | Dimensioni minime

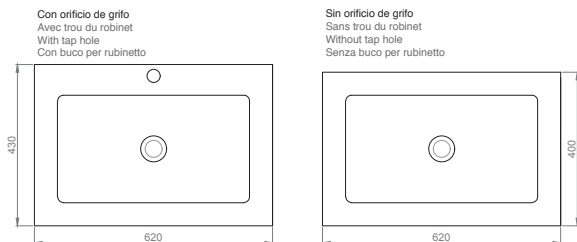

SENO OVAL | VASQUE OVAL | WASHBASIN OVAL | LAVABO OVAL

Dimensiones seno | Vasque dimensions | Washbasin dimensions | Dimensioni lavabo

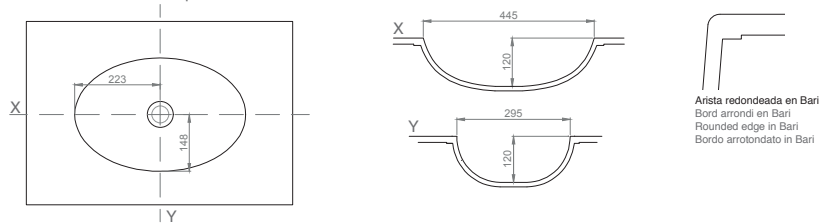

Rebosadero | Trop plein | Overflowl Troppo pieno

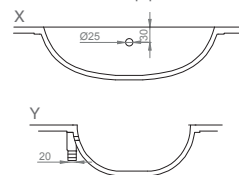

Configuraciones estándar | Configurations standard | Standard configurations | Configurazione standard

Un seno | Une vasque | Single integrated washbasin | Un lavabo integrato

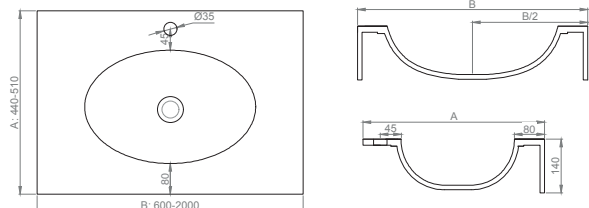

Dos senos | Double vasque | Double integrated washbasin | Doppio lavabo integrato

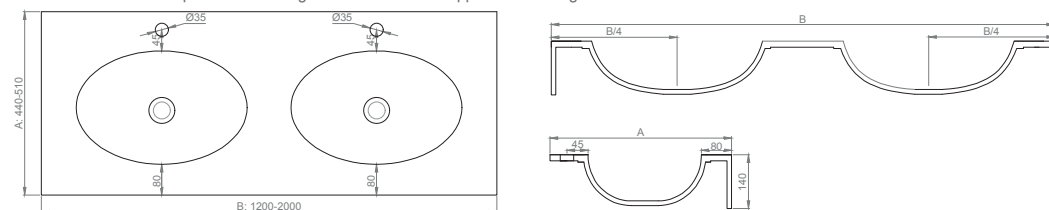

Distancias mínimas | Distances minimales | Minimum distances | Distanze minime

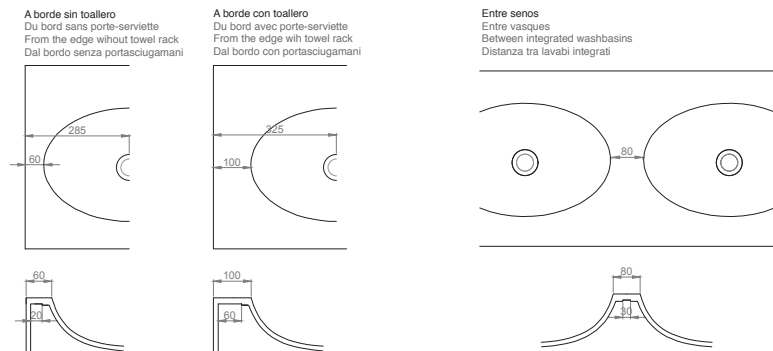

Tamaños mínimos | Dimensions minimales | Minimum sizes | Dimensioni minime

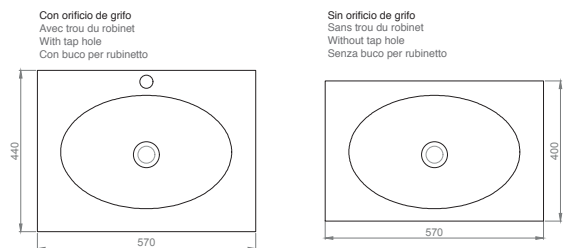

# ATENEA | BARI

## SENO CIRCULAR | VASQUE CIRCULAR | WASHBASIN CIRCULAR | LAVABO CIRCULAR

Dimensiones seno | Vasque dimensions | Washbasin dimensions | Dimensioni lavabo

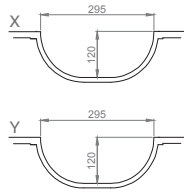
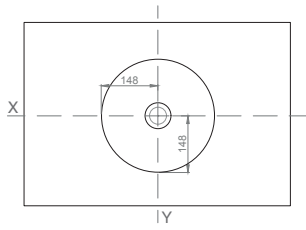

Arista redondeada en Bari  
Bord arrondi en Bari  
Rounded edge in Bari  
Bordo arrotondato in Bari

Rebosadero | Trop plein | Overflow | Troppo pieno

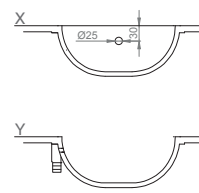

Configuraciones estándar | Configurations standard | Standard configurations | Configurazione standard

Un seno | Une vasque | Single integrated washbasin | Un lavabo integrato

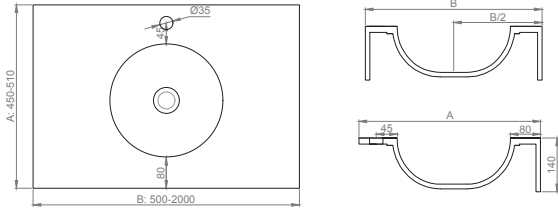

Dos senos | Double vasque | Double integrated washbasin | Doppio lavabo integrato

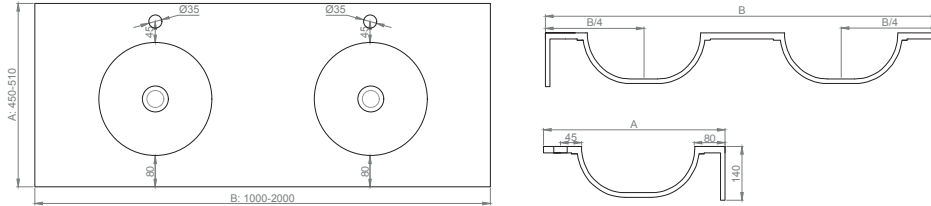

Distancias mínimas | Distances minimales | Minimum distances | Distanze minime

A borde sin toallero  
Du bord sans porte-serviette  
From the edge without towel rack  
Dal bordo senza portasciugamani

Entre senos  
Entre vasques  
Between integrated washbasins  
Distanza tra lavabi integrati

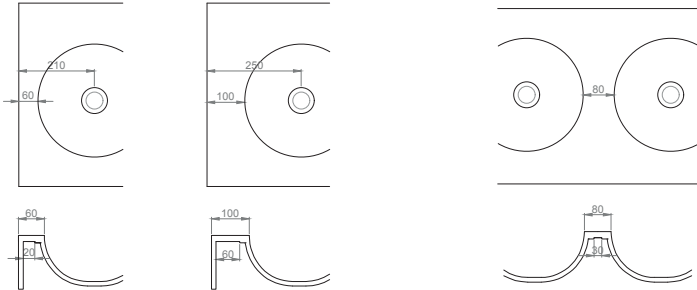

Tamaños mínimos | Dimensions minimales | Minimum sizes | Dimensioni minime

Con orificio de grifo  
Avec trou du robinet  
With tap hole  
Con buco per rubinetto

Sin orificio de grifo  
Sans trou du robinet  
Without tap hole  
Senza buco per rubinetto

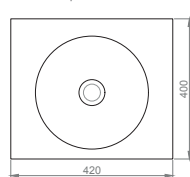
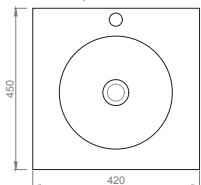

SENO MINI | VASQUE MINI | WASHBASIN MINI | LAVABO MINI

Dimensiones seno | Vasque dimensions | Washbasin dimensions | Dimensioni lavabo

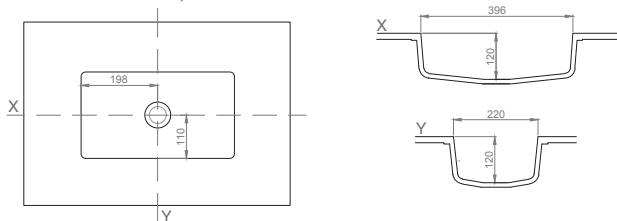

Rebosadero | Trop plein | Overflow | Troppo pieno

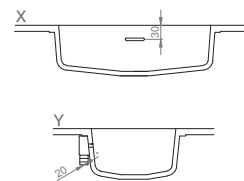

Centrado | Central | Central | Centrale

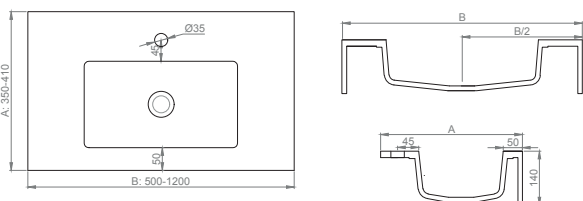

Desplazado | Latéral | Lateral | Laterale

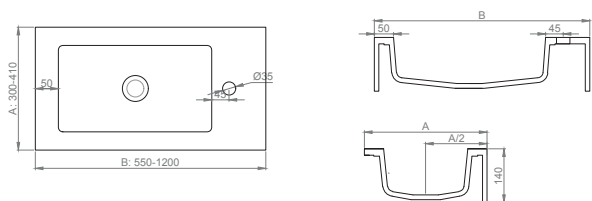

Distancias mínimas | Distances minimales | Minimum distances | Distanze minime

**A borde sin toallero**  
Du bord sans porte-serviette  
From the edge without towel rack  
Dal bordo senza portasciugamani

**A borde con toallero**  
Du bord avec porte-serviette  
From the edge with towel rack  
Dal bordo con portasciugamani

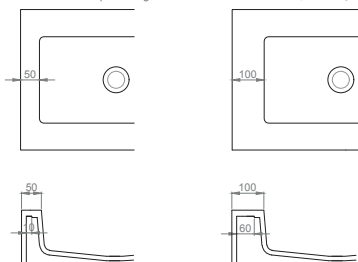

Tamaños mínimos | Dimensions minimales | Minimum sizes | Dimensioni minime

**Con orificio de grifo**  
Avec trou du robinet  
With tap hole  
Con buco per rubinetto

**Con orificio de grifo**  
Avec trou du robinet  
With tap hole  
Con buco per rubinetto

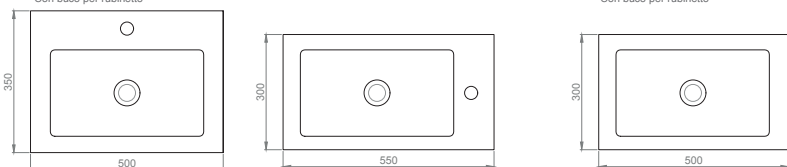



# ATENEA | BARI

SENO XL 85 | VASQUE XL 85 | WASHBASIN XL 85 | LAVABO XL 85

Dimensiones seno | Vasque dimensions | Washbasin dimensions | Dimensioni lavabo

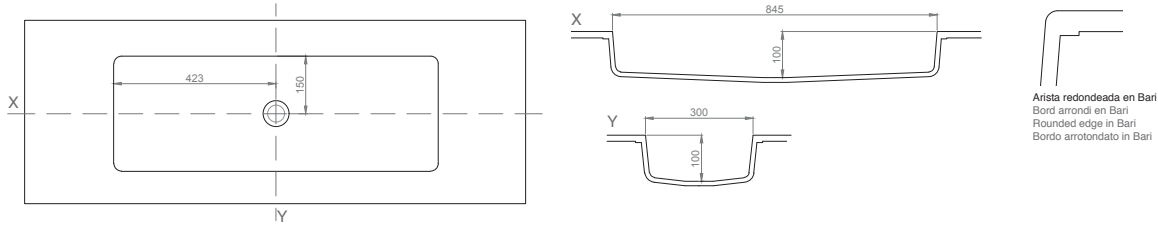

Rebosadero | Trop plein | Overflow | Troppo pieno

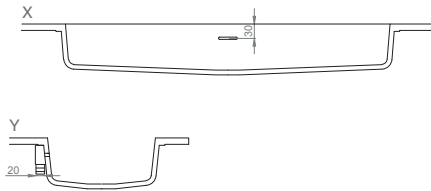

Configuraciones estándar | Configurations standard | Standard configurations | Configurazione standard

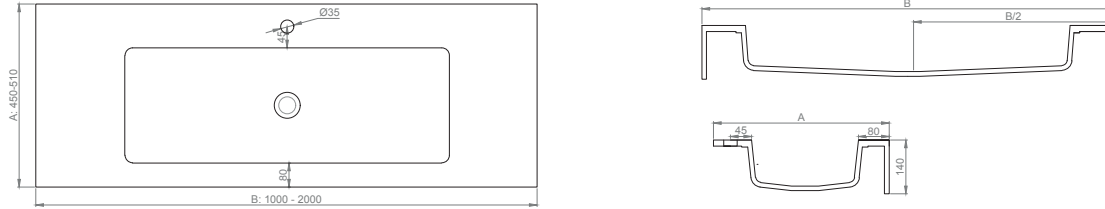

Distancias mínimas | Distances minimales | Minimum distances | Distanze minime

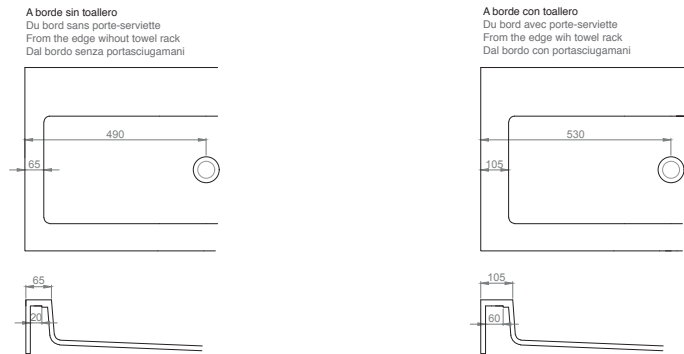

Tamaños mínimos | Dimensions minimales | Minimum sizes | Dimensioni minime

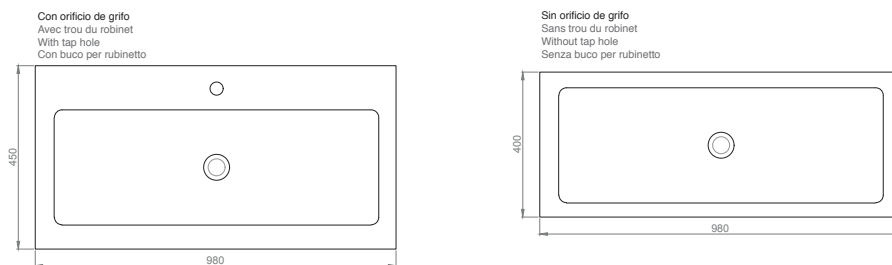

SENO XL 120 | VASQUE XL 120 | WASHBASIN XL 120 | LAVABO XL 120

Dimensiones seno | Vasque dimensions | Washbasin dimensions | Dimensioni lavabo

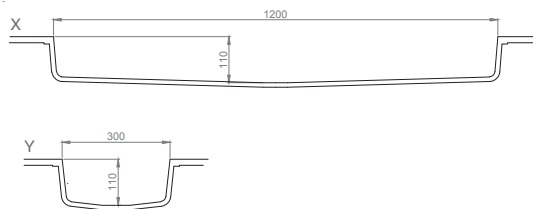
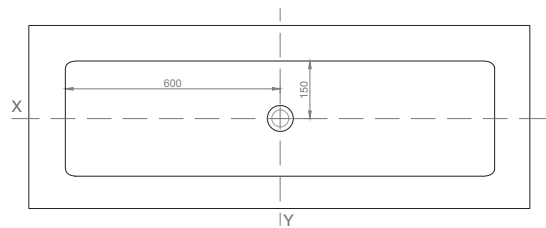

Arista redondeada en Bari  
Bord arrondi en Bari  
Rounded edge in Bari  
Bordo arrotondato in Bari

Rebosadero | Trop plein | Overflow | Troppo pieno

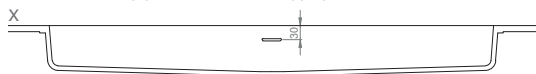

Configuraciones estándar | Configurations standard | Standard configurations | Configurazione standard

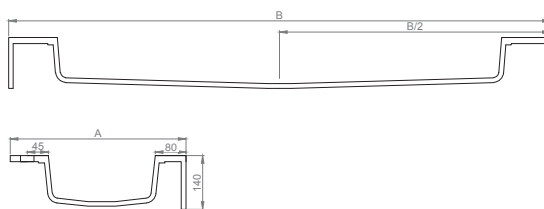
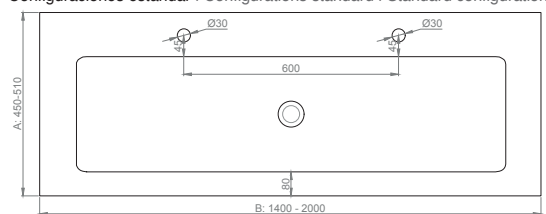

Distancias mínimas | Distances minimales | Minimum distances | Distanze minime

A borde sin toallero  
Du bord sans porte-serviette  
From the edge without towel rack  
Dal bordo senza portasciugamani

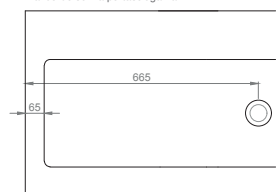

A borde con toallero  
Du bord avec porte-serviette  
From the edge with towel rack  
Dal bordo con portasciugamani

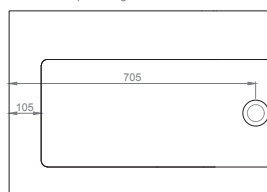

Tamaños mínimos | Dimensions minimales | Minimum sizes | Dimensioni minime

Con orificio de grifo  
Avec trou du robinet  
With tap hole  
Con buco per rubinetto

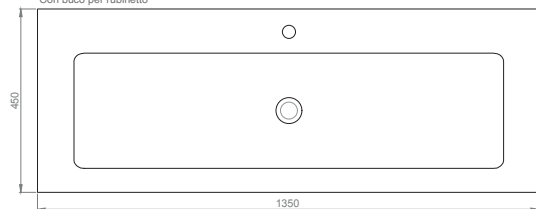

Sin orificio de grifo  
Sans trou du robinet  
Without tap hole  
Senza buco per rubinetto

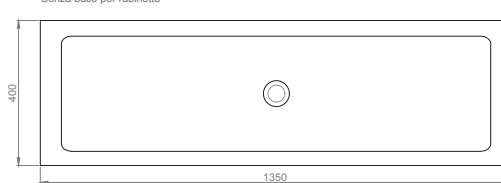

# VENTO CF | OLIMPIA CF

## VENTO 40

Dimensiones seno | Vasque dimensions | Washbasin dimensions | Dimensioni lavabo

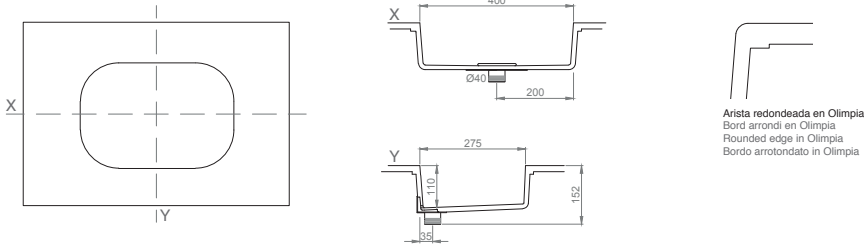

Configuraciones estándar | Configurations standard | Standard configurations | Configurazione standard

Un seno | Une vasque | Single integrated washbasin | Un lavabo integrato

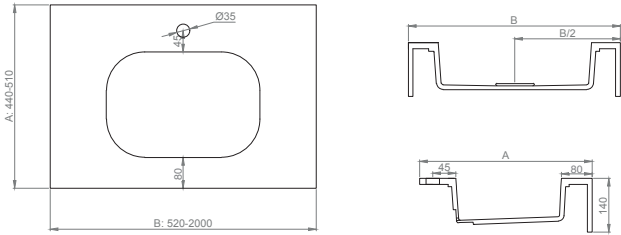

Dos senos | Double vasque | Double integrated washbasin | Doppio lavabo integrato

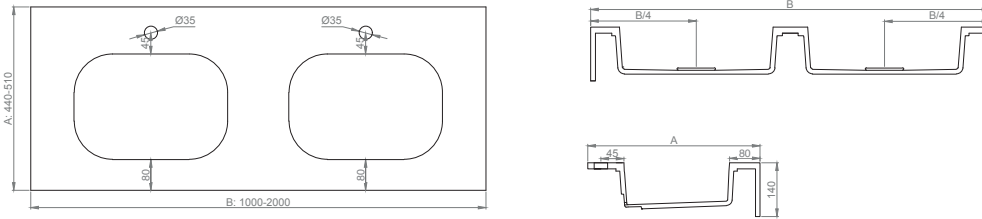

Distancias mínimas | Distances minimales | Minimum distances | Distanze minime

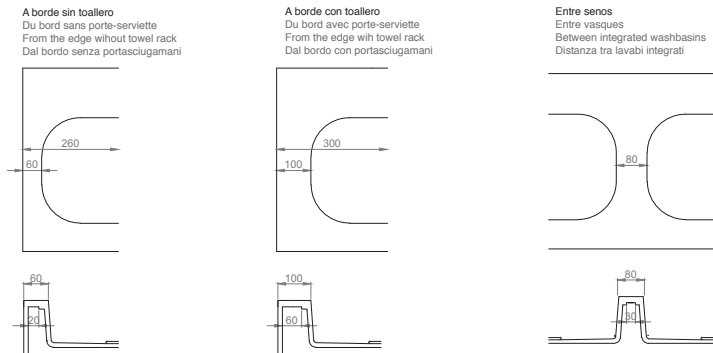

Tamaños mínimos | Dimensions minimales | Minimum sizes | Dimensioni minime



VENTO 60

Dimensiones seno | Vasque dimensions | Washbasin dimensions | Dimensioni lavabo

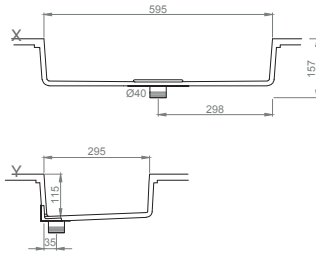
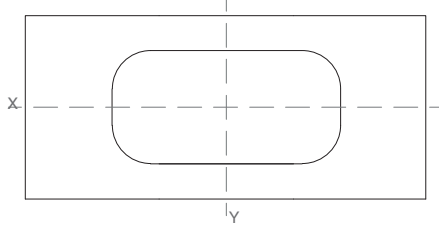

Configuraciones estándar | Configurations standard | Standard configurations | Configurazione standard

Un seno | Une vasque | Single integrated washbasin | Un lavabo integrato

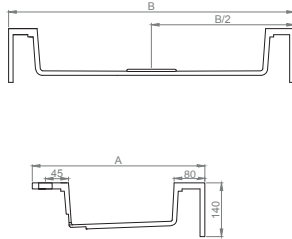
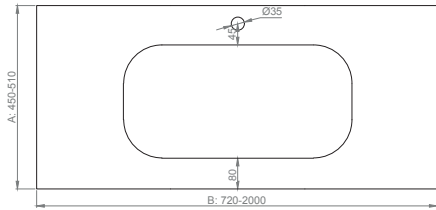

Dos senos | Double vasque | Double integrated washbasin | Doppio lavabo integrato

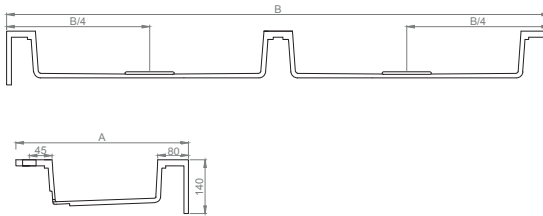
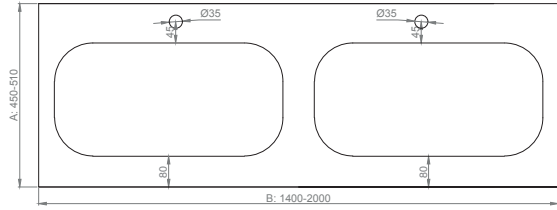

Distancias mínimas | Distances minimales | Minimum distances | Distanze minime

A borde sin toallero  
Du bord sans porte-serviette  
From the edge without towel rack  
Dal bordo senza portasciugamani

A borde con toallero  
Du bord avec porte-serviette  
From the edge with towel rack  
Dal bordo con portasciugamani

Entre senos  
Entre vasques  
Between integrated washbasins  
Distanza tra lavabi integrati

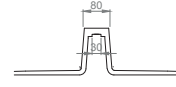
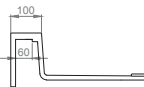
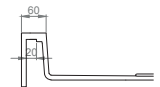
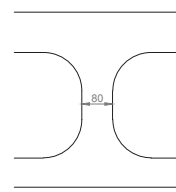
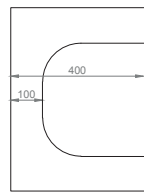
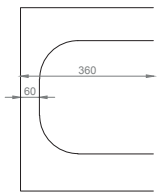

Tamaños mínimos | Dimensions minimales | Minimum sizes | Dimensioni minime

Con orificio de grifo  
Avec trou du robinet  
With tap hole  
Con buco per rubinetto

Sin orificio de grifo  
Sans trou du robinet  
Without tap hole  
Senza buco per rubinetto

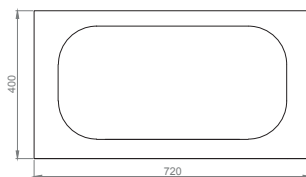
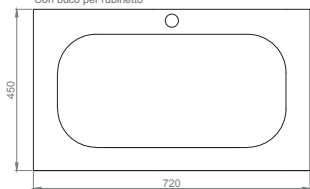

# COSMO CF

## SENO ESTANDAR | VASQUE ESTANDAR | WASHBASIN ESTANDAR | LAVABO ESTANDAR

### Dimensiones seno | Vasque dimensions | Washbasin dimensions | Dimensioni lavabo

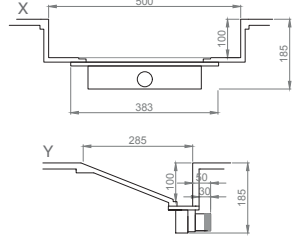
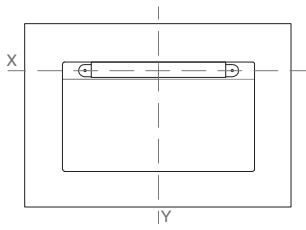

### Tapa | Couvercle | Top | Copertura

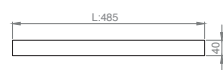

Masa interna no coloreada  
Masse interne non colorée  
Internal mass not colored  
Massa interna non colorata

La visión de la válvula para una estatura media de 175 cm. podría producirse a partir de 6 metros.  
La vision de la valvule pour une hauteur de 175 cm pourrait se produire à partir de 6 mètres.  
For an average height of 175cm, the valve can be set up with anything from a 6m head.  
La valvola può essere vista da una persona con una statura media di 175 cm a partire da 6 metri.

## Configuraciones estándar | Configurations standard | Standard configurations | Configurazione standard

### Un seno | Une vasque | Single integrated washbasin | Un lavabo integrato

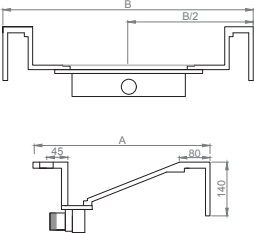
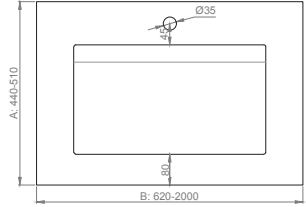

### Dos senos | Double vasque | Double integrated washbasin | Doppio lavabo integrato

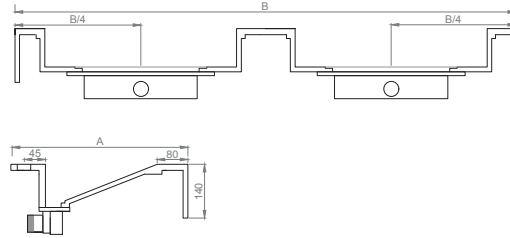
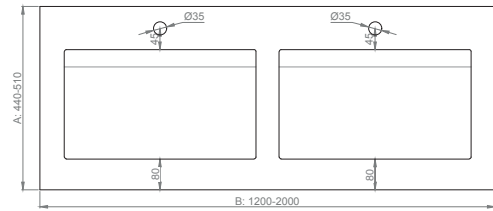

## Distancias mínimas | Distances minimales | Minimum distances | Distanze minime

**A borde sin toallero**  
Du bord sans porte-serviette  
From the edge without towel rack  
Dal bordo senza portasciugamani

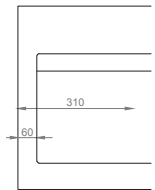

**A borde con toallero**  
Du bord avec porte-serviette  
From the edge with towel rack  
Dal bordo con portasciugamani

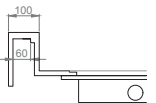
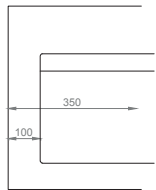

**Entre senos**  
Entre vasques  
Between integrated washbasins  
Distanza tra lavabi integrati

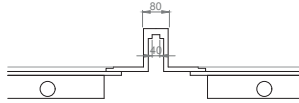
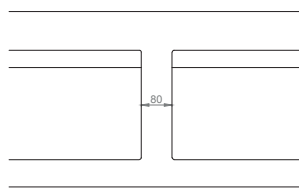

## Tamaños mínimos | Dimensions minimales | Minimum sizes | Dimensioni minime

**Con orificio de grifo**  
Avec trou du robinet  
With tap hole  
Con buco per rubinetto

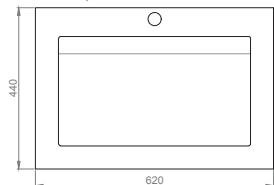

**Sin orificio de grifo**  
Sans trou du robinet  
Without tap hole  
Senza buco per rubinetto

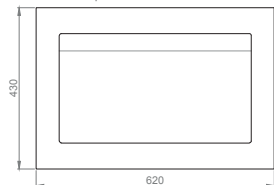

SENO XL 85 | VASQUE XL 85 | WASHBASIN XL 85 | LAVABO XL 85

Dimensiones seno | Vasque dimensions | Washbasin dimensions | Dimensioni lavabo

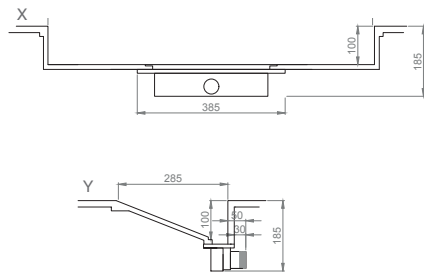
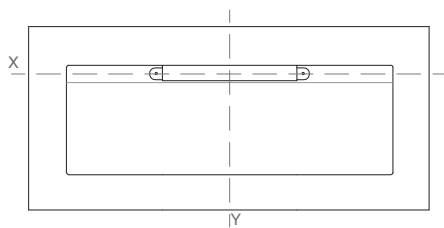

Tapa | Couverture | Top | Copertura

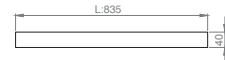

Masa interna no coloreada  
Masse interne non colorée  
Internal mass not colored  
Massa interna non colorata

La visión de la válvula para una estatura media de 175 cm, podría producirse a partir de 6 metros.  
La vision de la valvule pour une hauteur de 175 cm pourrait se produire à partir de 6 mètres.  
For an average height of 175cm, the valve can be set up with anything from a 6m head.  
La valvola può essere vista da una persona con una statura media di 175 cm a partire da 6 metri.

Configuraciones estándar | Configurations standard | Standard configurations | Configurazione standard

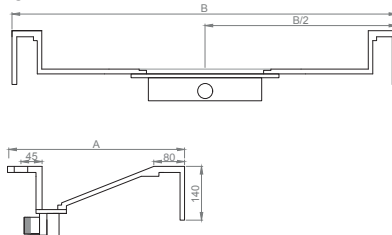
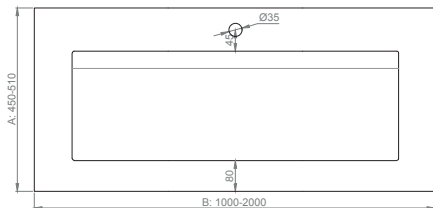

Distancias mínimas | Distances minimales | Minimum distances | Distanze minime

A borde sin toallero  
Du bord sans porte-serviette  
From the edge without towel rack  
Dal bordo senza portasciugamani

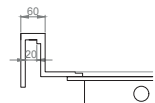
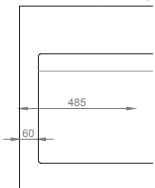

A borde con toallero  
Du bord avec porte-serviette  
From the edge with towel rack  
Dal bordo con portasciugamani

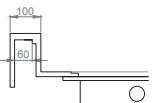
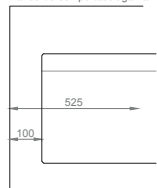

Tamaños mínimos | Dimensions minimales | Minimum sizes | Dimensioni minime

Con orificio de grifo  
Avec trou du robinet  
With tap hole  
Con buco per rubinetto

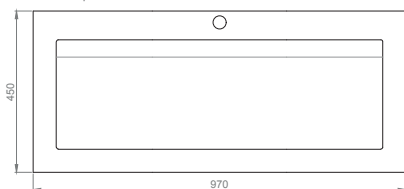

Sin orificio de grifo  
Sans trou du robinet  
Without tap hole  
Senza buco per rubinetto

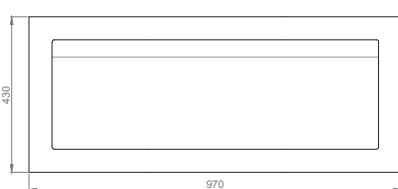

# COSMO CF

SENO XL 120 | VASQUE XL 120 | WASHBASIN XL 120 | LAVABO XL 120

Dimensiones seno | Vasque dimensions | Washbasin dimensions | Dimensioni lavabo

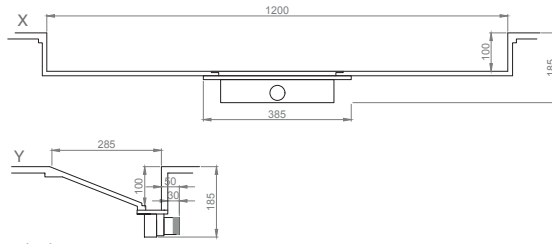
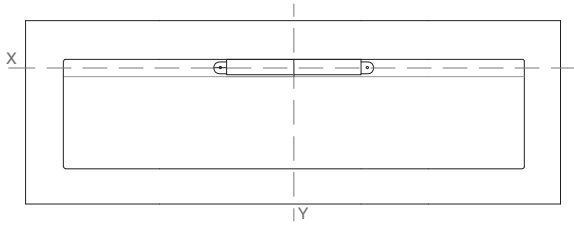

La visión de la válvula para una estatura media de 175 cm. podría producirse a partir de 6 metros. La vision de la valve pour une hauteur de 175 cm pourrait se produire à partir de 6 mètres. For an average height of 175cm, the valve can be set up with anything from a 6m head. La valvola può essere vista da una persona con una statura media di 175 cm a partire da 6 metri.

Configuraciones estándar | Configurations standard | Standard configurations | Configurazione standard

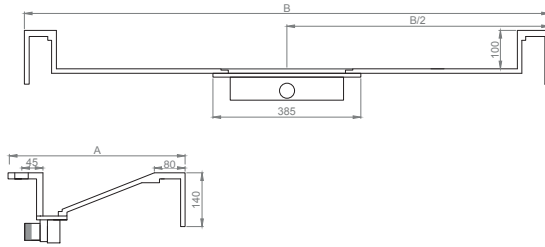
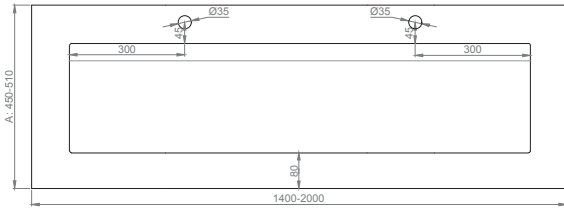

Tapa | Couvercle | Top | Copertura

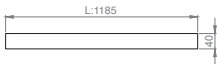

Masa interna no coloreada  
Masse interne non colorée  
Internal mass not colored  
Massa interna non colorata

Distancias mínimas | Distances minimales | Minimum distances | Distanze minime

A borde sin toallero  
Du bord sans porte-serviette  
From the edge without towel rack  
Dal bordo senza portasciugamani

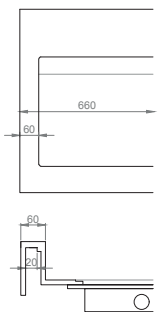

A borde con toallero  
Du bord avec porte-serviette  
From the edge with towel rack  
Dal bordo con portasciugamani

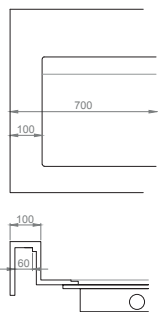

Tamaños mínimos | Dimensions minimales | Minimum sizes | Dimensioni minime

Con orificio de grifo  
Avec trou du robinet  
With tap hole  
Con buco per rubinetto

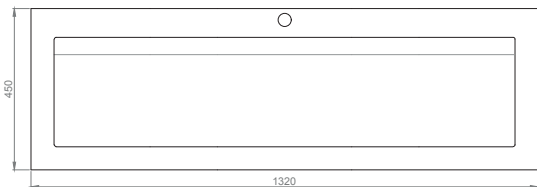

Sin orificio de grifo  
Sans trou du robinet  
Without tap hole  
Senza buco per rubinetto

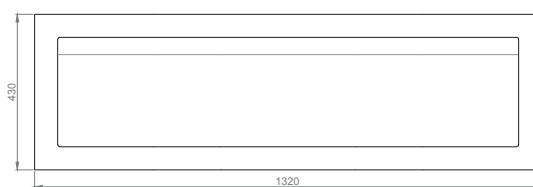

SENO ESTANDAR | VASQUE ESTARNDAR | WASHBASIN ESTANDAR | LAVABO ESTANDAR

Dimensiones seno | Vasque dimensions | Washbasin dimensions | Dimensioni lavabo

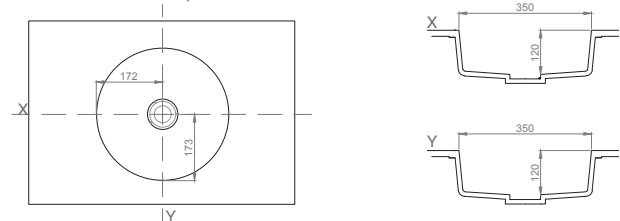

Tapa | Couvercle | Top | Copri piletta



Configuraciones estándar | Configurations standard | Standard configurations | Configurazione standard

Un seno | Une vasque | Single integrated washbasin | Un lavabo integrato

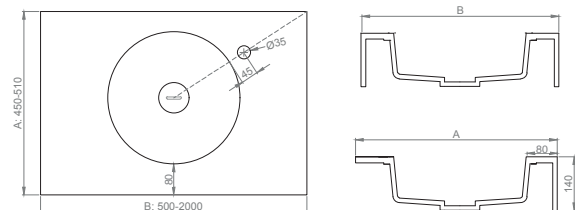

Dos senos | Double vasque | Double integrated washbasin | Doppio lavabo integrato

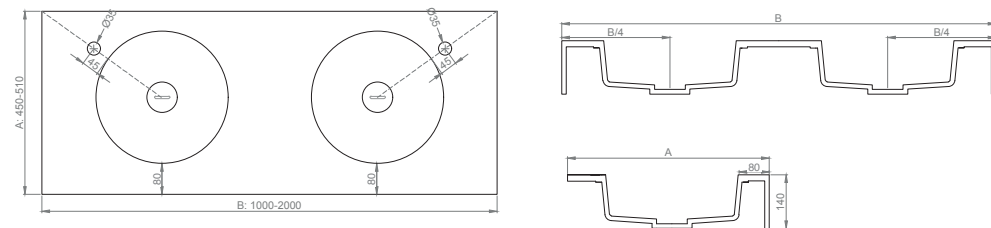

Distancias mínimas | Distances minimales | Minimum distances | Distanze minime

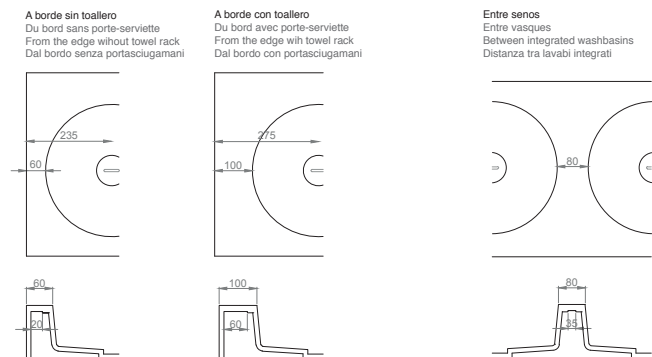

Tamaños mínimos | Dimensions minimales | Minimum sizes | Dimensioni minime

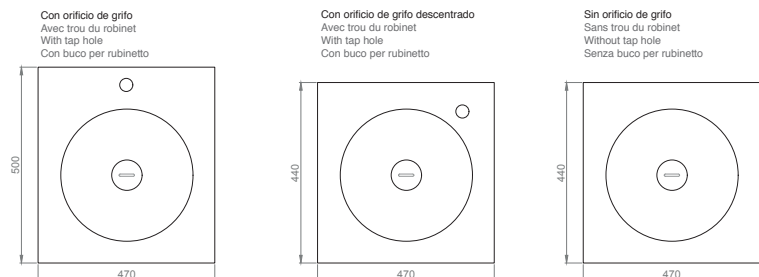



# SENDA CF

## SENO ESTANDAR | VASQUE ESTANDAR | WASHBASIN ESTANDAR | LAVABO ESTANDAR

Dimensiones seno | Vasque dimensions | Washbasin dimensions | Dimensioni lavabo

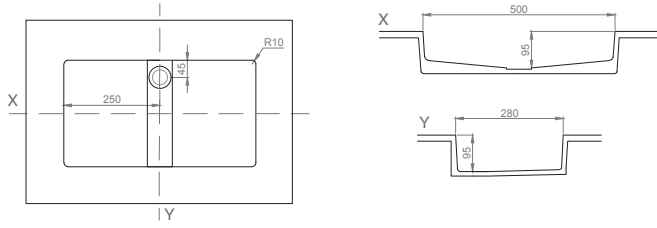

Rejilla | Grille | Grid | Griglia



Inox AISI 316

## Configuraciones estándar | Configurations standard | Standard configurations | Configurazione standard

Un seno | Une vasque | Single integrated washbasin | Un lavabo integrato

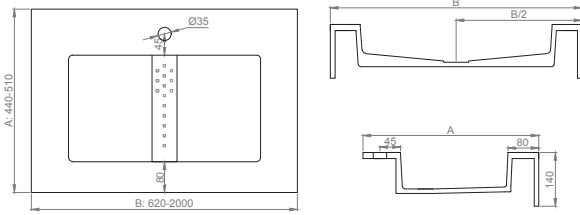

## Dos senos | Double vasque | Double integrated washbasin | Doppio lavabo integrato

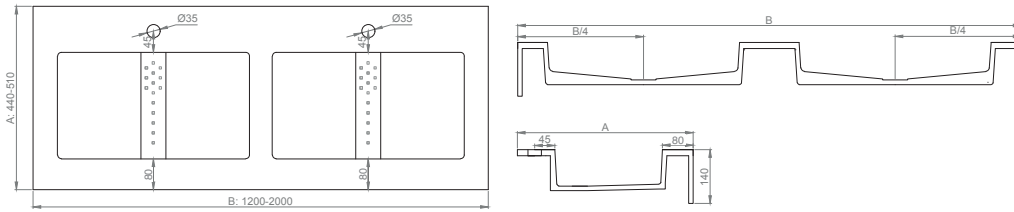

## Distancias mínimas | Distances minimales | Minimum distances | Distanze minime

**A borde sin toallero**  
Du bord sans porte-serviette  
From the edge without towel rack  
Dal bordo senza portasciugamani

**A borde con toallero**  
Du bord avec porte-serviette  
From the edge with towel rack  
Dal bordo con portasciugamani

**Entre senos**  
Entre vasques  
Between integrated washbasins  
Distanza tra lavabi integrati

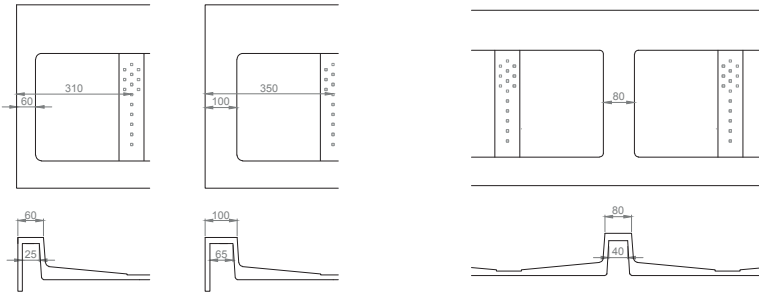

## Tamaños mínimos | Dimensions minimales | Minimum sizes | Dimensioni minime

**Con orificio de grifo**  
Avec trou du robinet  
With tap hole  
Con buco per rubinetto

**Sin orificio de grifo**  
Sans trou du robinet  
Without tap hole  
Senza buco per rubinetto

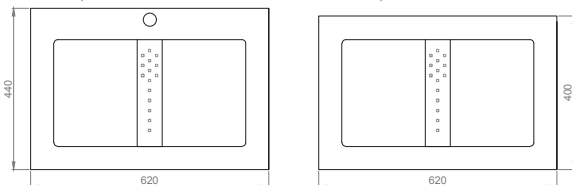

Dimensiones | Dimensions | Dimensioni

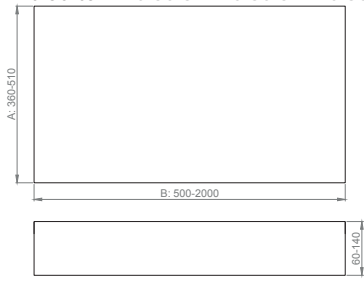

Cortes a medida | Découps sur mesure | Cut to size | Tagli su misura

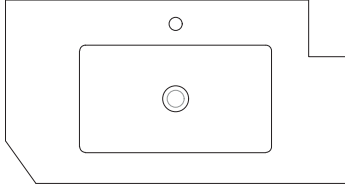

Mecanizados estándar  
Trous standard  
Standard holes  
Fori standard



Faldones | Retombées | Skirts | Altezze

Estándar



XL



\*Solo lisa y Solid surface  
\*Uniquement lisa et Solid Surface  
\*Only lisa and Solid surface  
\*Solo lisa e Solid surface

Toalleros | Porte-seviettes | Towel racks | Portasciugamani

Estándar 35 x 3,5cm  
Standard 35 x 3,5cm  
Standard 35 x 3,5cm  
Standard 35 x 3,5cm

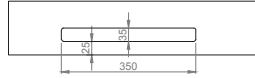

Mini 25 x 3,5cm

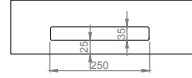

Estándar 40 x 3,5cm  
Standard 40 x 3,5cm  
Standard 40 x 3,5cm  
Standard 40 x 3,5cm

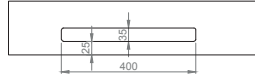

XL 80 x 3,5cm



A medida  
Sur mesure  
Custom made  
Su misura



Bandeja | Plateau | Tray | Vassoio

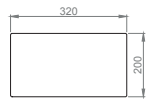

Masa interna no coloreada  
Masse interne non colorée  
Internal mass not colored  
Massa interna non colorata

Válvula click | Bonde click | Drain click | Piletta click



Masa interna no coloreada  
Masse interne non colorée  
Internal mass not colored  
Massa interna non colorata

Copetes | Plinthes | Backsplashes | Alzatine

Estándar H 4cm  
Standard H 4cm  
Standard H 4cm  
Standard H 4cm

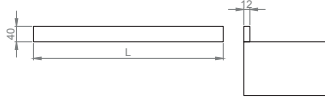

Integrado recto H 4cm  
À angle droit intégrée H 4cm  
90 degree integrated H 4cm  
Integrata ad angolo retto H 4cm



Integrado curvo H 4cm  
Concave intégrée H 4cm  
Coved integrated H 4cm  
Integrata arrotondata H 4cm

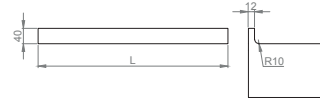

A medida H 5-30cm  
Sur mesure H 5-30cm  
Custom made H 5-30cm  
Su misura H 5-30cm

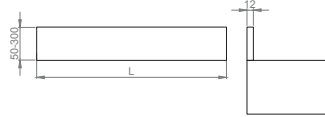

Integrado recto a media H 5-30cm  
À angle droit intégrée sur mesure H 5-30cm  
90 degree integrated Custom made H 5-30cm  
Integrata ad angolo retto Su misura H 5-30cm

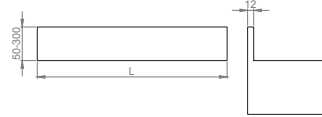

Integrado curvo a media H 5-30cm  
Concave intégrée sur mesure H 5-30cm  
Coved integrated custom made H 5-30cm  
Integrata arrotondata su misura H 5-30cm



Mecanizados estándar en copete



Mecanizados a media en copete



Soportes | Supports | Brackets | Staffe

Estándar

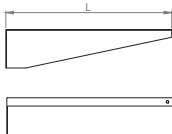

Mini/auxiliar

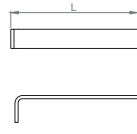



# SELENE | HYDRA

## SENO ESTÁNDAR | VASQUE ESTÁNDAR | WASHBASIN ESTÁNDAR | LAVABO ESTÁNDAR

Dimensiones seno | Vasque dimensions | Washbasin dimensions | Dimensioni lavabo

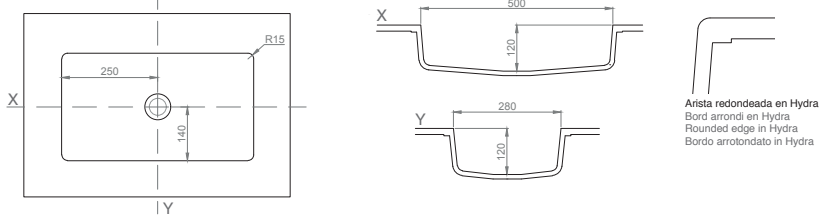

Rebosadero | Trop plein | Overflow | Troppo pieno

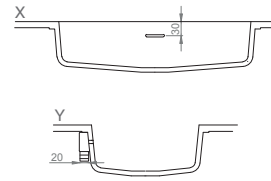

## Configuraciones estándar | Configurations standard | Standard configurations | Configurazione standard

Un seno | Une vasque | Single integrated washbasin | Un lavabo integrato

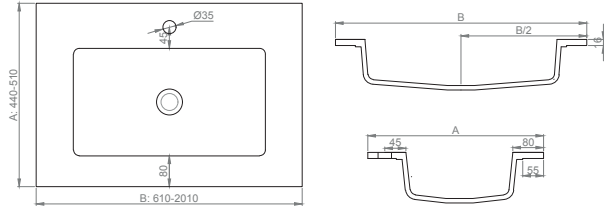

Dos senos | Double vasque | Double integrated washbasin | Doppio lavabo integrato

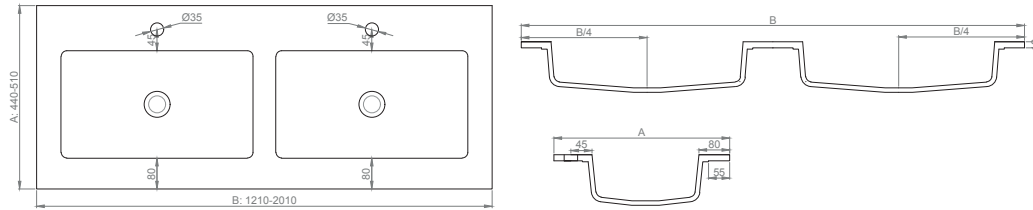

## Distancias mínimas | Distances minimales | Minimum distances | Distanze minime

A borde sin toallero  
Du bord sans porte-serviette  
From the edge without towel rack  
Dal bordo senza portasciugamani

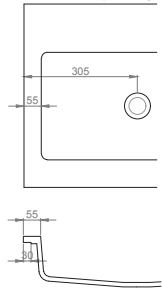

Entre senos  
Entre vasques  
Between integrated washbasins  
Distanza tra lavabi integrati

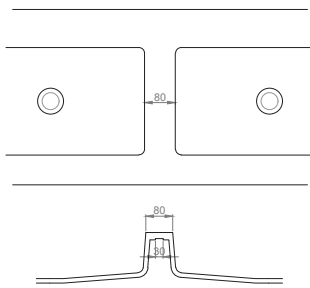

Huero mínimo en mueble 560x340x130mm  
Minimal espace dans meuble 560x340x130mm  
Minimum cabinet gap 560x340x130mm  
Spazio minimo in mobile 560x340x130mm

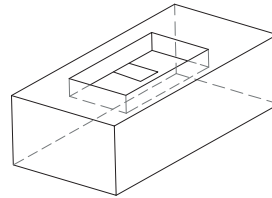

## Tamaños mínimos | Dimensions minimales | Minimum sizes | Dimensioni minime

Con orificio de grifo  
Avec trou du robinet  
With tap hole  
Con buco per rubinetto

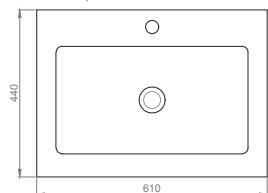

Sin orificio de grifo  
Sans trou du robinet  
Without tap hole  
Senza buco per rubinetto

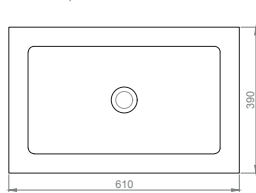

SENO OVAL | VASQUE OVAL | WASHBASIN OVAL | LAVABO OVAL

Dimensiones seno | Vasque dimensions | Washbasin dimensions | Dimensioni lavabo

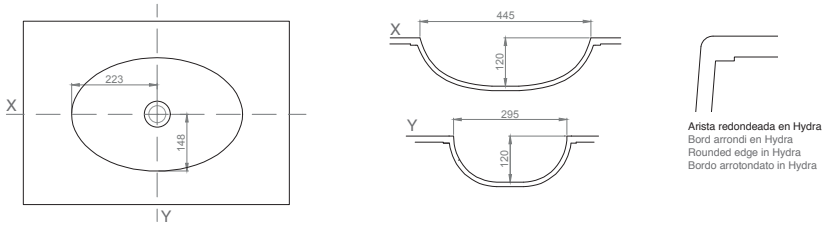

Rebosadero | Trop plein | Overflow | Troppo pieno

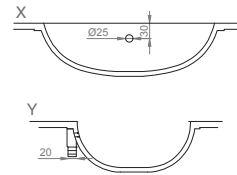

Configuraciones estándar | Configurations standard | Standard configurations | Configurazione standard

Un seno | Une vasque | Single integrated washbasin | Un lavabo integrato

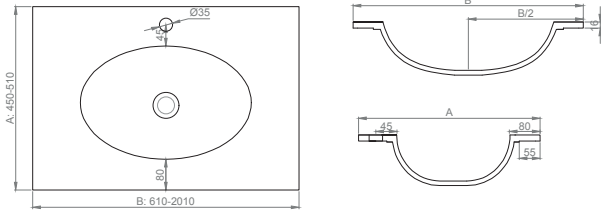

Dos senos | Double vasque | Double integrated washbasin | Doppio lavabo integrato

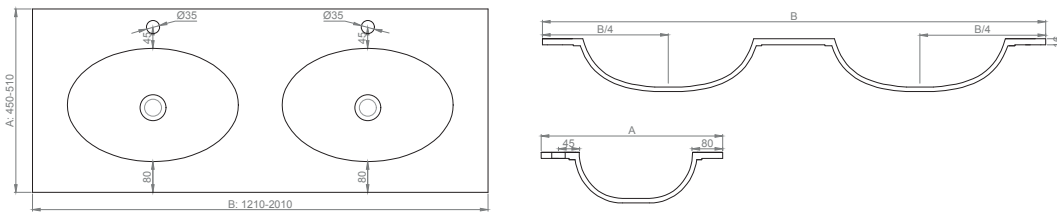

Distancias mínimas | Distances minimales | Minimum distances | Distanze minime

A borde sin toallero  
Du bord sans porte-serviette  
From the edge without towel rack  
Dal bordo senza portasciugamani

Entre senos  
Entre vasques  
Between integrated washbasins  
Distanza tra lavabi integrati

Huaco mínimo en mueble 520x340x130mm  
Minimal espace dans meuble 520x340x130mm  
Minimum cabinet gap 520x340x130mm  
Spazio minimo in mobile 520x340x130mm

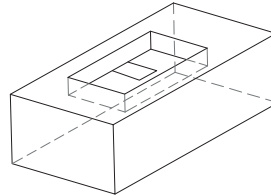
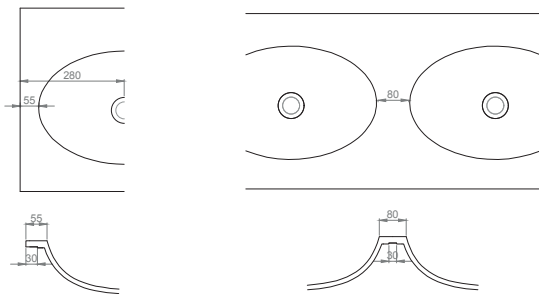

Tamaños mínimos | Dimensions minimales | Minimum sizes | Dimensioni minime

Con orificio de grifo  
Avec trou du robinet  
With tap hole  
Con buco per rubinetto

Sin orificio de grifo  
Sans trou du robinet  
Without tap hole  
Senza buco per rubinetto

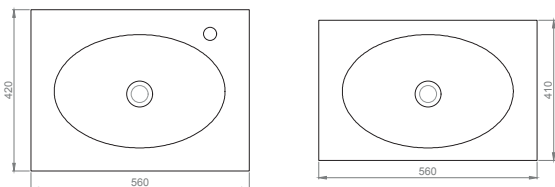

# SELENE | HYDRA

## SENO CIRCULAR | VASQUE CIRCULAR | WASHBASIN CIRCULAR | LAVABO CIRCULAR

Dimensiones seno | Vasque dimensions | Washbasin dimensions | Dimensioni lavabo

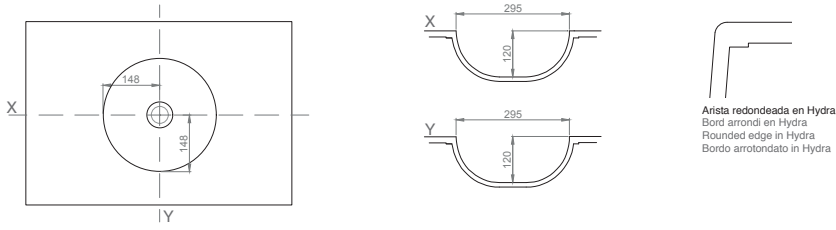

Rebosadero | Trop plein | Overflow | Troppo pieno

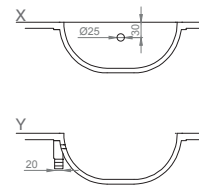

Configuraciones estándar | Configurations standard | Standard configurations | Configurazione standard

Un seno | Une vasque | Single integrated washbasin | Un lavabo integrato

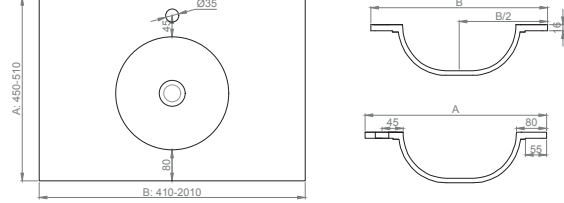

Dos senos | Double vasque | Double integrated washbasin | Doppio lavabo integrato

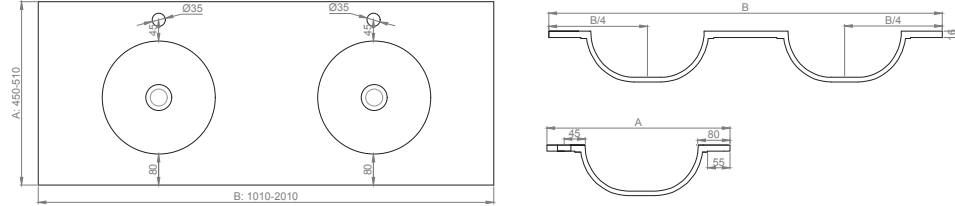

Distancias mínimas | Distances minimales | Minimum distances | Distanze minime

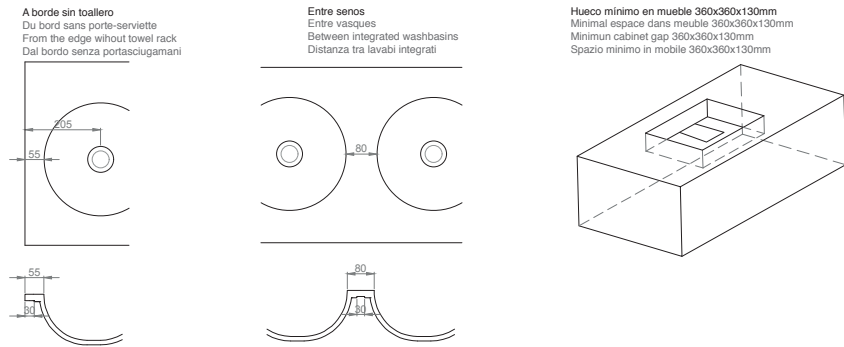

Tamaños mínimos | Dimensions minimales | Minimum sizes | Dimensioni minime

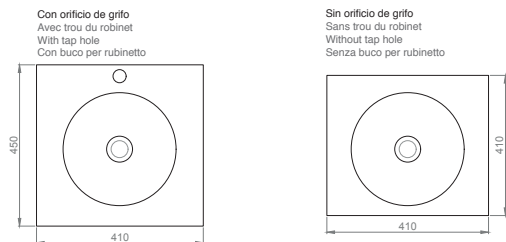

SENO MINI | VASQUE MINI | WASHBASIN MINI | LAVABO MINI

Dimensiones seno | Vasque dimensions | Washbasin dimensions | Dimensioni lavabo

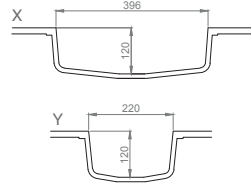
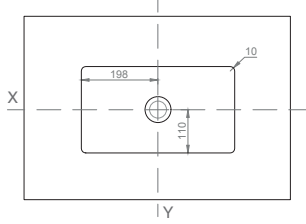

Arista redondeada en Hydra  
Bord arrondi en Hydra  
Rounded edge in Hydra  
Bordo arrotondato in Hydra

Rebosadero | Trop plein | Overflow | Troppo pieno

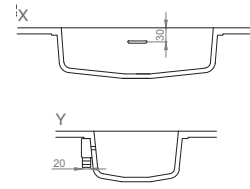

Centrado | Central | Central | Centrale

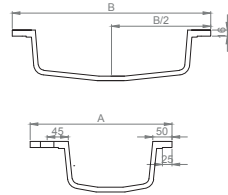
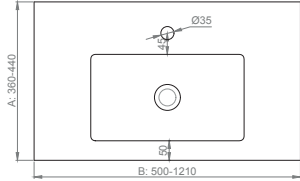

Desplazado | Latéral | Lateral | Laterale

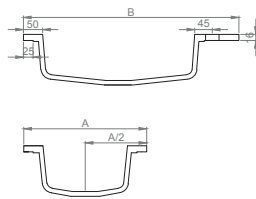
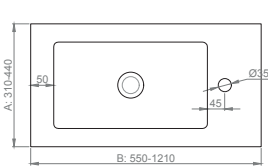

Distancias mínimas | Distances minimales | Minimum distances | Distanze minime

A borde sin toallero  
Du bord sans porte-serviette  
From the edge without towel rack  
Dal bordo senza portasciugamani

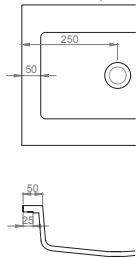

Hueco mínimo en mueble 450x280x130mm  
Minimal espace dans meuble 450x280x130mm  
Minimum cabinet gap 450x280x130mm  
Spazio minimo in mobile 450x280x130mm

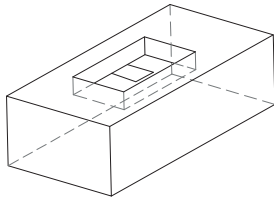

Tamaños mínimos | Dimensions minimales | Minimum sizes | Dimensioni minime

Con orificio de grifo  
Avec trou du robinet  
With tap hole  
Con buco per rubinetto

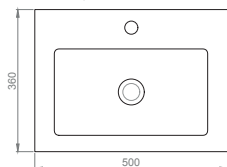

Sin orificio de grifo  
Sans trou du robinet  
Without tap hole  
Senza buco per rubinetto

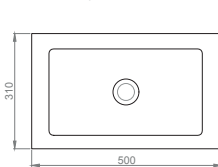
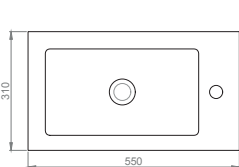



# SELENE | HYDRA

SENO XL 85 | VASQUE XL 85 | WASHBASIN XL 85 | LAVABO XL 85

Dimensiones seno | Vasque dimensions | Washbasin dimensions | Dimensioni lavabo

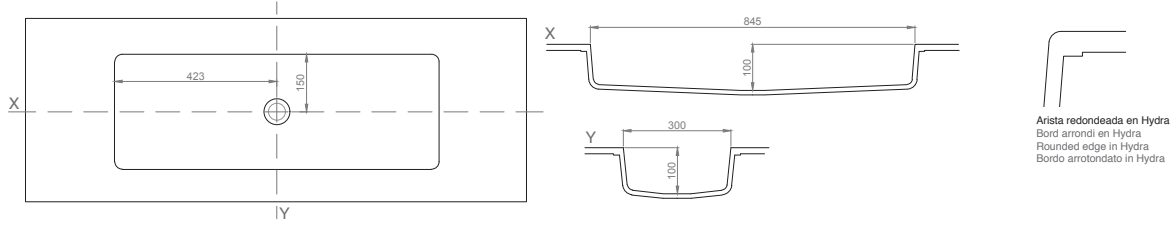

Rebosadero | Trop plein | Overflow | Troppo pieno

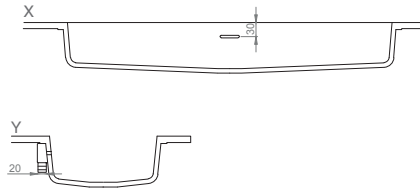

Configuraciones estándar | Configurations standard | Standard configurations | Configurazione standard

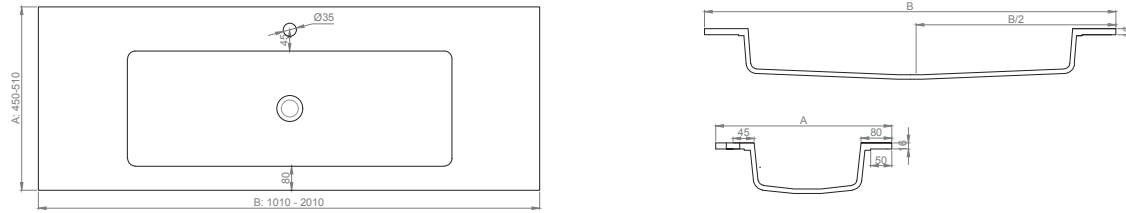

Distancias mínimas | Distances minimales | Minimum distances | Distanze minime

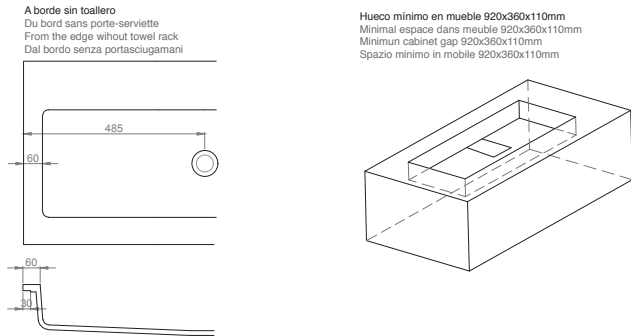

Tamaños mínimos | Dimensions minimales | Minimum sizes | Dimensioni minime

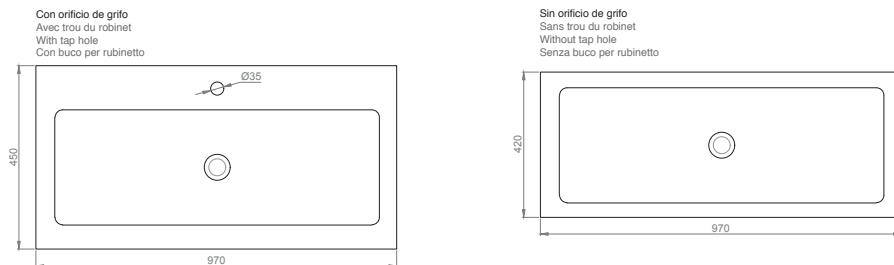

SENO XL 120 | VASQUE XL 120 | WASHBASIN XL 120 | LAVABO XL 120

Dimensiones seno | Vasque dimensions | Washbasin dimensions | Dimensioni lavabo

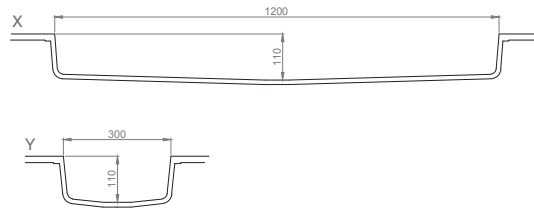
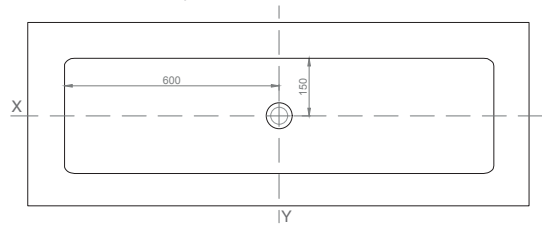

Arista redondeada en Hydra  
Bord arrondi en Hydra  
Rounded edge in Hydra  
Bordo arrotondato in Hydra

Rebosadero | Trop plein | Overflow | Troppo pieno

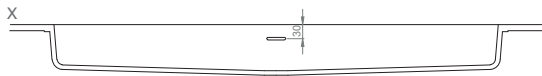

Configuraciones estándar | Configurations standard | Standard configurations | Configurazione standard

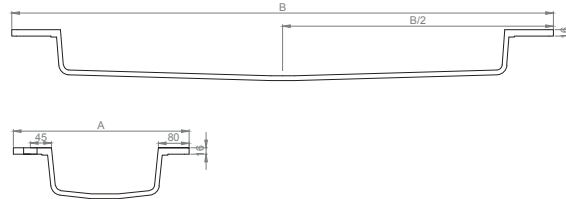
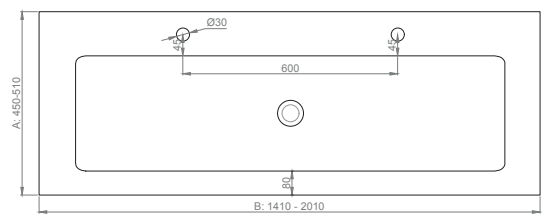

Distancias mínimas | Distances minimales | Minimum distances | Distanze minime

A borde sin toallero  
Du bord sans porte-serviette  
From the edge without towel rack  
Dal bordo senza portasciugamani

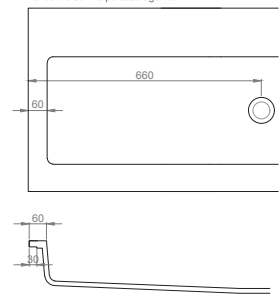

Hueco mínimo en mueble 1260x360x130mm  
Minimal espace dans meuble 1260x360x130mm  
Minimum cabinet gap 1260x360x130mm  
Spazio minimo in mobile 1260x360x130mm

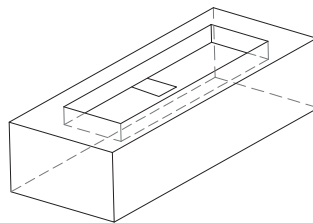

Tamaños mínimos | Dimensions minimales | Minimum sizes | Dimensioni minime

Con orificio de grifo  
Avec trou du robinet  
With tap hole  
Con buco per rubinetto

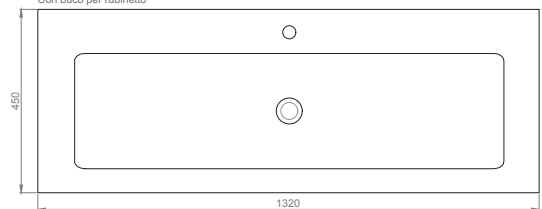

Sin orificio de grifo  
Sans trou du robinet  
Without tap hole  
Senza buco per rubinetto

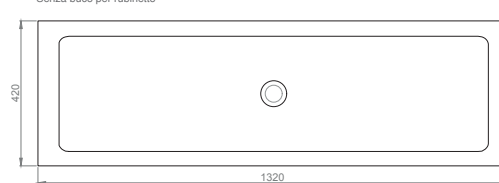

# VENTO SF | OLIMPIA SF

## VENTO 40

Dimensiones seno | Vasque dimensions | Washbasin dimensions | Dimensioni lavabo

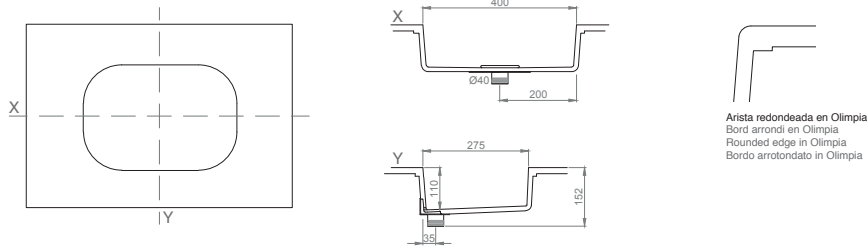

Configuraciones estándar | Configurations standard | Standard configurations | Configurazione standard

Un seno | Une vasque | Single integrated washbasin | Un lavabo integrato

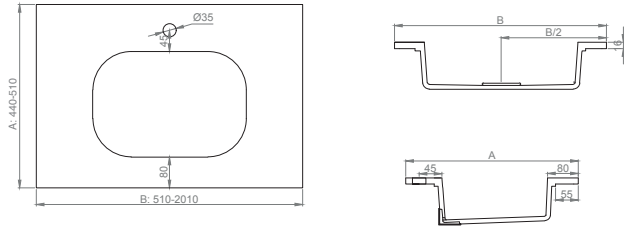

Dos senos | Double vasque | Double integrated washbasin | Doppio lavabo integrato

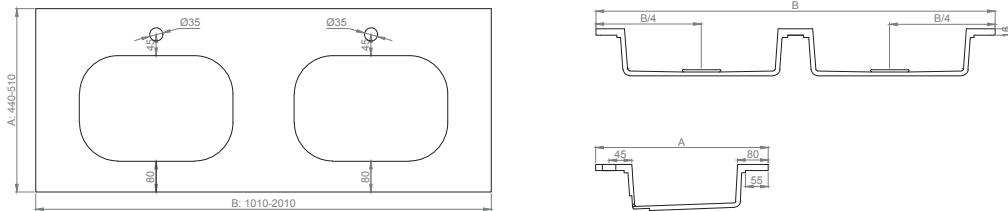

Distancias mínimas | Distances minimales | Minimum distances | Distanze minime

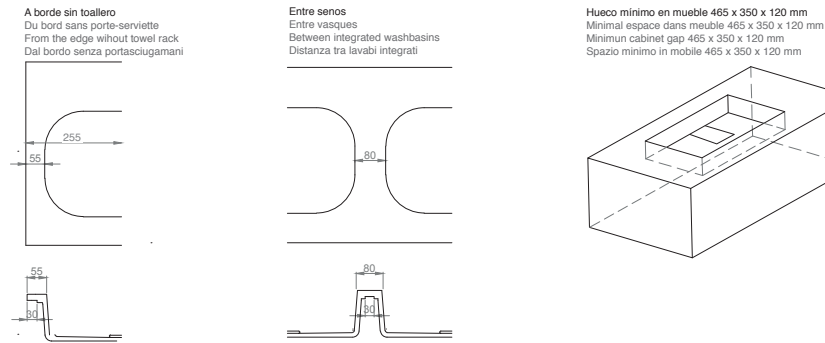

Tamaños mínimos | Dimensions minimales | Minimum sizes | Dimensioni minime



VENTO 60

Dimensiones seno | Vasque dimensions | Washbasin dimensions | Dimensioni lavabo

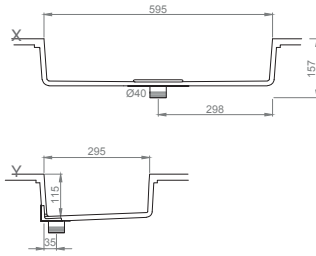
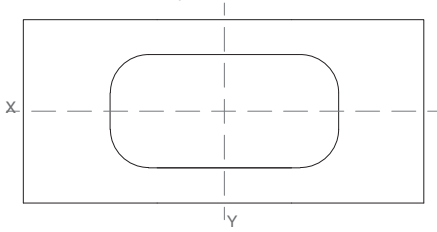

Arista redondeada en Olimpia  
Bord arrondi en Olimpia  
Rounded edge in Olimpia  
Bordo arrotondato in Olimpia

Configuraciones estándar | Configurations standard | Standard configurations | Configurazione standard

Un seno | Une vasque | Single integrated washbasin | Un lavabo integrato

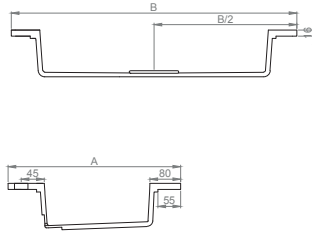
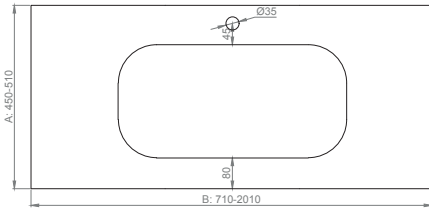

Dos senos | Double vasque | Double integrated washbasin | Doppio lavabo integrato

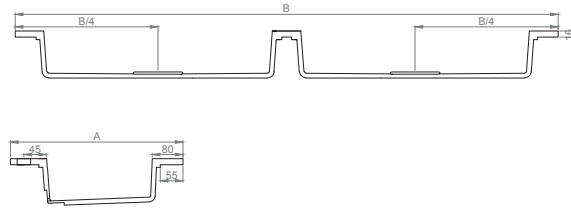
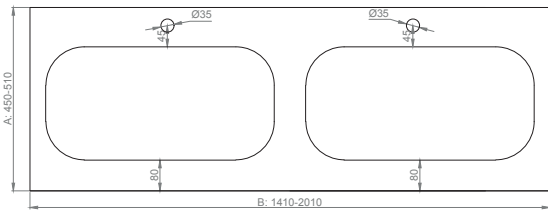

Distancias mínimas | Distances minimales | Minimum distances | Distanze minime

A borde sin toallero  
Du bord sans porte-serviette  
From the edge without towel rack  
Dal bordo senza portasciugamani

Entre senos  
Entre vasques  
Between integrated washbasins  
Distanza tra lavabi integrati

Hueco mínimo en mueble 660 x 355 x 130 mm  
Minimal espace dans meuble 660 x 355 x 130 mm  
Minimun cabinet gap 660 x 355 x 130 mm  
Spazio minimo in mobile 660 x 355 x 130 mm

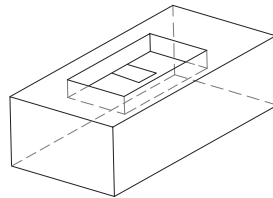
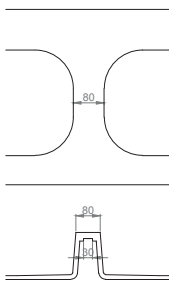
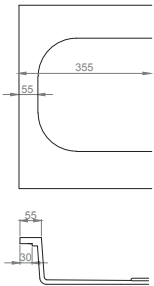

Tamaños mínimos | Dimensions minimales | Minimum sizes | Dimensioni minime

Con orificio de grifo  
Avec trou du robinet  
With tap hole  
Con buco per rubinetto

Sin orificio de grifo  
Sans trou du robinet  
Without tap hole  
Senza buco per rubinetto

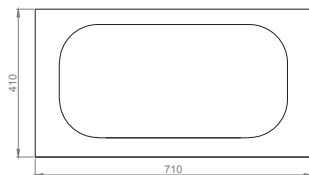
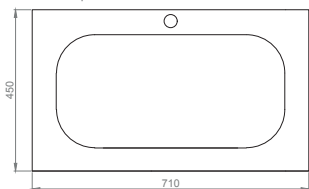

# COSMO SF

## SENO ESTANDAR | VASQUE ESTANDAR | WASHBASIN ESTANDAR | LAVABO ESTANDAR

Dimensiones seno | Vasque dimensions | Washbasin dimensions | Dimensioni lavabo

Tapa | Couvercle | Top | Copertura

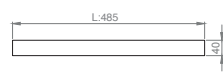
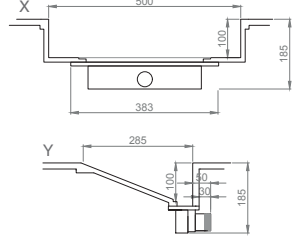
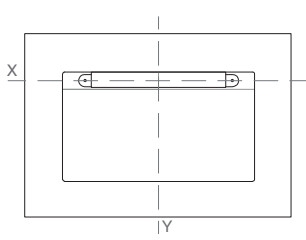

Masa interna no coloreada  
Masse interne non colorée  
Internal mass not colored  
Massa interna non colorata

## Configuraciones estándar | Configurations standard | Standard configurations | Configurazione standard

Un seno | Une vasque | Single integrated washbasin | Un lavabo integrato

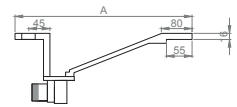
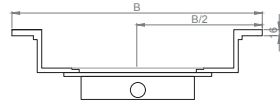
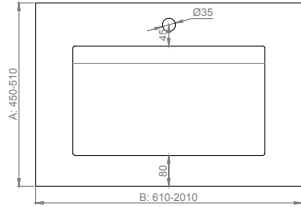

Dos senos | Double vasque | Double integrated washbasin | Doppio lavabo integrato

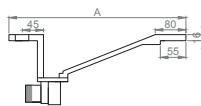
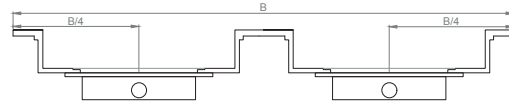
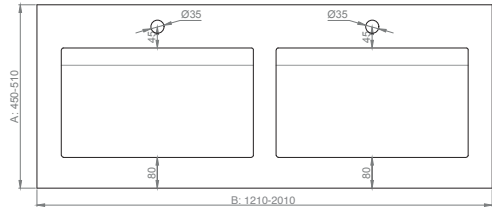

## Distancias mínimas | Distances minimales | Minimum distances | Distanze minime

A borde sin toallero  
Du bord sans porte-serviette  
From the edge without towel rack  
Dal bordo senza portasciugamani

Entre senos  
Entre vasques  
Between integrated washbasins  
Distanza tra lavabi integrati

Hueco mínimo en mueble 530 x 330 x 170 mm  
Minimal espace dans meuble 530 x 330 x 170 mm  
Minimum cabinet gap 530 x 330 x 170 mm  
Spazio minimo in mobile 530 x 330 x 170 mm

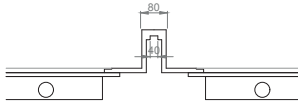
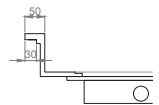
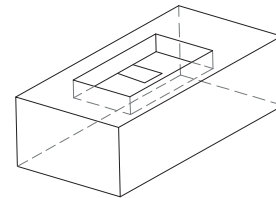
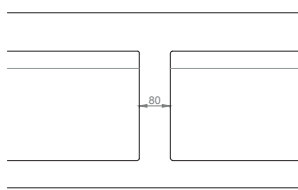
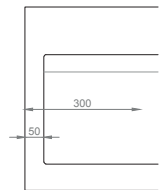

## Tamaños mínimos | Dimensions minimales | Minimum sizes | Dimensioni minime

Con orificio de grifo  
Avec trou du robinet  
With tap hole  
Con buco per rubinetto

Sin orificio de grifo  
Sans trou du robinet  
Without tap hole  
Senza buco per rubinetto

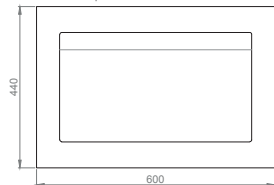
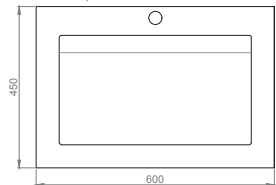

SENO XL 85 | VASQUE XL 85 | WASHBASIN XL 85 | LAVABO XL 85

Dimensiones seno | Vasque dimensions | Washbasin dimensions | Dimensioni lavabo

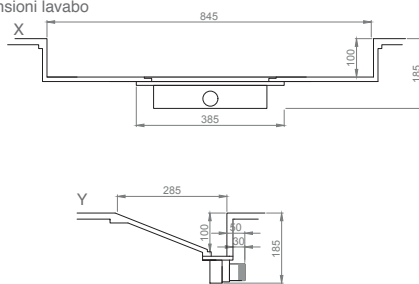
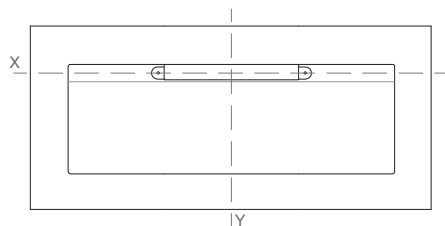

Tapa | Couverture | Top | Copertura

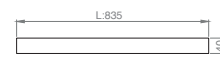

Masa interna no coloreada  
Masse interne non colorée  
Internal mass not colored  
Massa interna non colorata

Configuraciones estándar | Configurations standard | Standard configurations | Configurazione standard

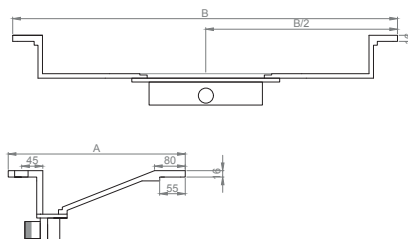
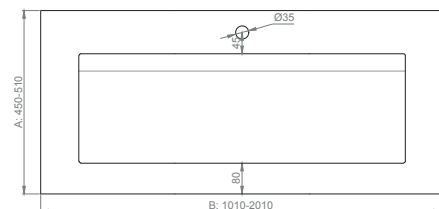

Distancias mínimas | Distances minimales | Minimum distances | Distanze minime

A borde sin toallero  
Du bord sans porte-serviette  
From the edge without towel rack  
Dal bordo senza portasciugamani

Hueco mínimo en mueble 900 x 330 x 170 mm  
Minimal espace dans meuble 900 x 330 x 170 mm  
Minimum cabinet gap 900 x 330 x 170 mm  
Spazio minimo in mobile 900 x 330 x 170 mm

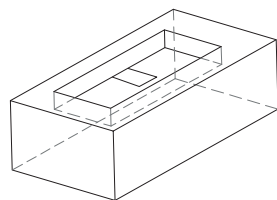
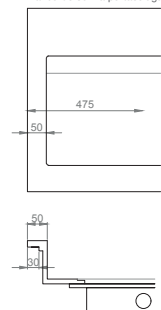

Tamaños mínimos | Dimensions minimales | Minimum sizes | Dimensioni minime

Con orificio de grifo  
Avec trou du robinet  
With tap hole  
Con buco per rubinetto

Sin orificio de grifo  
Sans trou du robinet  
Without tap hole  
Senza buco per rubinetto

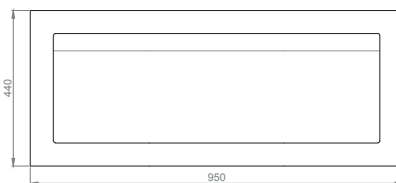
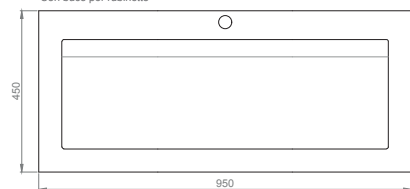

# COSMO SF

SENO XL 120 | VASQUE XL 120 | WASHBASIN XL 120 | LAVABO XL 120

Dimensiones seno | Vasque dimensions | Washbasin dimensions | Dimensioni lavabo

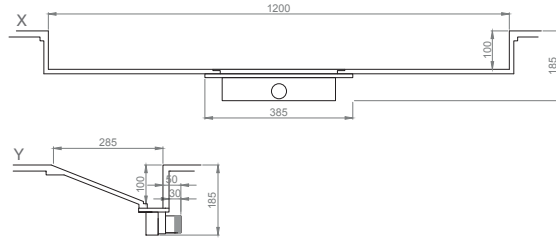
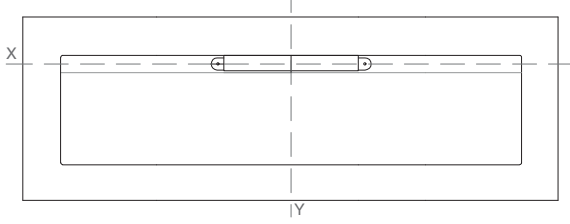

Configuraciones estándar | Configurations standard | Standard configurations | Configurazione standard

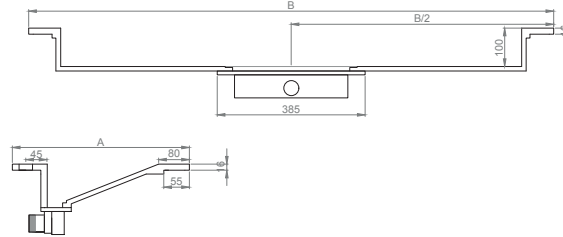
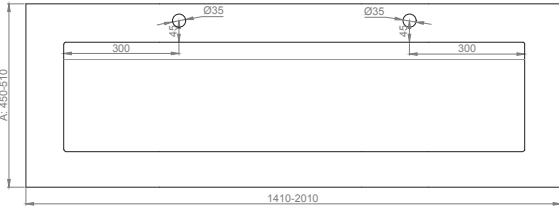

Tapa | Couvercle | Top | Copertura

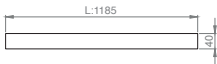

Masa interna no coloreada  
Masse interne non colorée  
Internal mass not colored  
Massa interna non colorata

Distancias mínimas | Distances minimales | Minimum distances | Distanze minime

A borde sin toallero  
Du bord sans porte-serviette  
From the edge without towel rack  
Dal bordo senza portasciugamani

Hueco mínimo en mueble 1250 x 330 x 170 mm  
Minimal espace dans meuble 1250 x 330 x 170 mm  
Minimum cabinet gap 1250 x 330 x 170 mm  
Spazio minimo in mobile 1250 x 330 x 170 mm

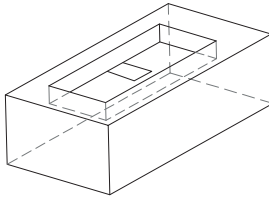
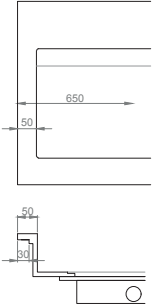

Tamaños mínimos | Dimensions minimales | Minimum sizes | Dimensioni minime

Con orificio de grifo  
Avec trou du robinet  
With tap hole  
Con buco per rubinetto

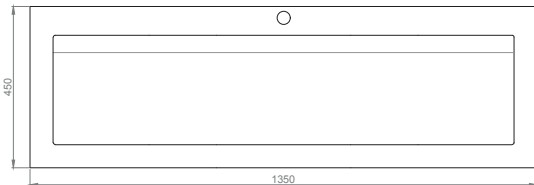

Sin orificio de grifo  
Sans trou du robinet  
Without tap hole  
Senza buco per rubinetto

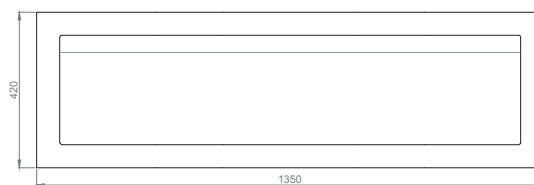

SENO ESTANDAR | VASQUE ESTANDAR | WASHBASIN ESTANDAR | LAVABO ESTANDAR

Dimensiones seno | Vasque dimensions | Washbasin dimensions | Dimensioni lavabo

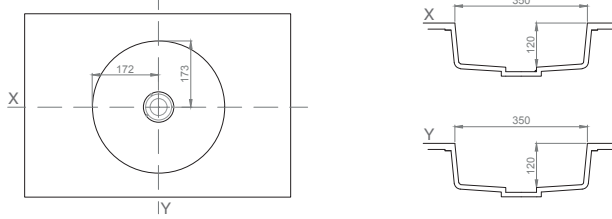

Tapa | Couvercle | Top | Copri piletta



Configuraciones estándar | Configurations standard | Standard configurations | Configurazione standard

Un seno | Une vasque | Single integrated washbasin | Un lavabo integrato

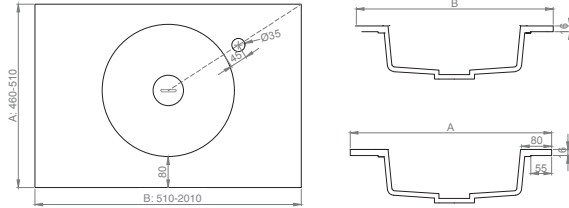

Dos senos | Double vasque | Double integrated washbasin | Doppio lavabo integrato

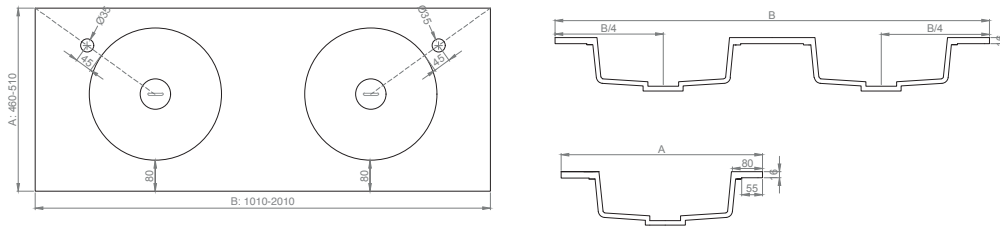

Distancias mínimas | Distances minimales | Minimum distances | Distanze minime

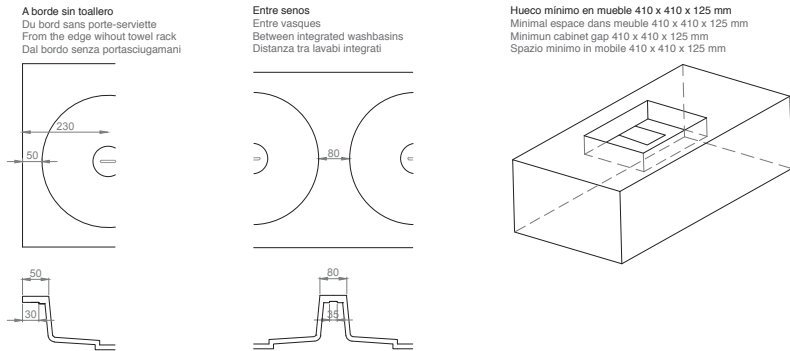

Tamaños mínimos | Dimensions minimales | Minimum sizes | Dimensioni minime

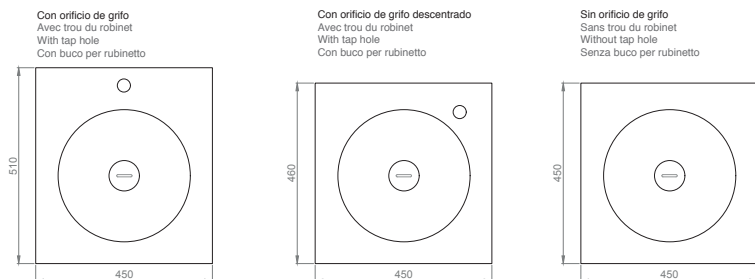



# SENDA SF

## SENO ESTANDAR | VASQUE ESTANDAR | WASHBASIN ESTANDAR | LAVABO ESTANDAR

Dimensiones seno | Vasque dimensions | Washbasin dimensions | Dimensioni lavabo

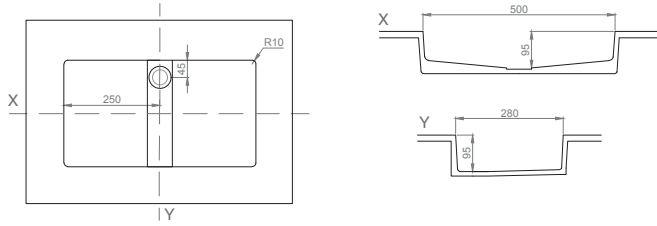

Rejilla | Grille | Grid | Griglia



## Configuraciones estándar | Configurations standard | Standard configurations | Configurazione standard

Un seno | Une vasque | Single integrated washbasin | Un lavabo integrato

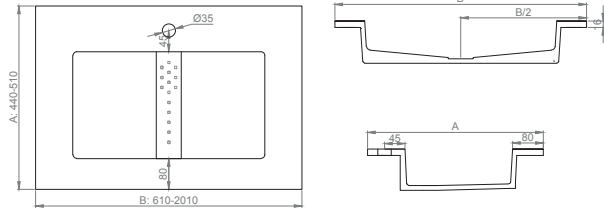

Dos senos | Double vasque | Double integrated washbasin | Doppio lavabo integrato

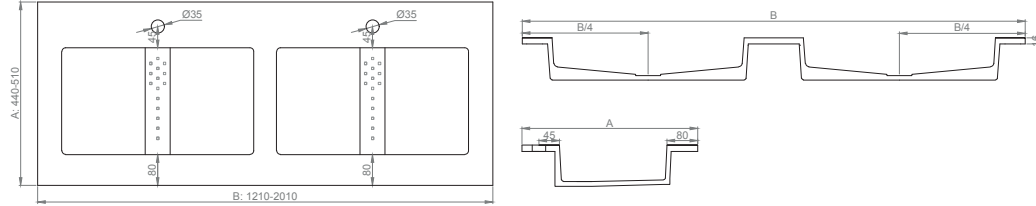

## Distancias mínimas | Distances minimales | Minimum distances | Distanze minime

**A borde sin toallero**  
Du bord sans porte-serviette  
From the edge without towel rack  
Dal bordo senza portasciugamani

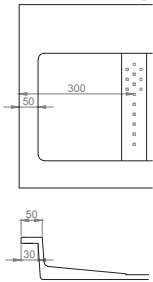

**Entre senos**  
Entre vasques  
Between integrated washbasins  
Distanza tra lavabi integrati

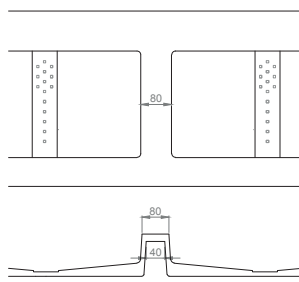

**Huero mínimo en mueble 540 x 320 x 110 mm**  
Minimal espace dans meuble 540 x 320 x 110 mm  
Minimum cabinet gap 540 x 320 x 110 mm  
Spazio minimo in mobile 540 x 320 x 110 mm

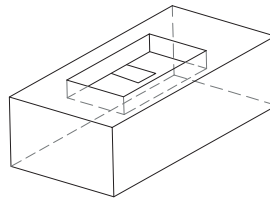

## Tamaños mínimos | Dimensions minimales | Minimum sizes | Dimensioni minime

**Con orificio de grifo**  
Avec trou du robinet  
With tap hole  
Con buco per rubinetto

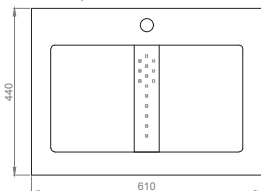

**Sin orificio de grifo**  
Sans trou du robinet  
Without tap hole  
Senza buco per rubinetto

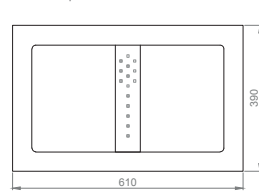

Dimensiones | Dimensions | Dimensioni | Dimensiuni

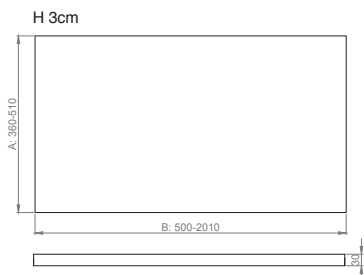
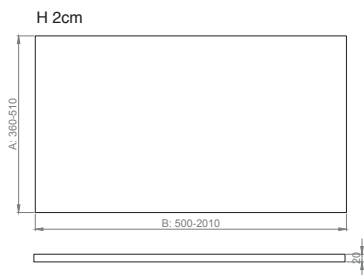

Cortes a medida | Découpes sur mesure | Cut to size | Tagli su misura

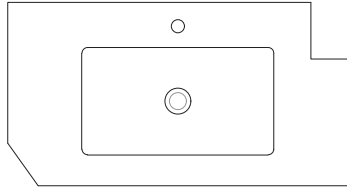

Mecanizados estándar  
Trous standard  
Standard holes  
Fori standard



Cortes curvos | Découpes en courbe | Curved cuts | Tagli curvi

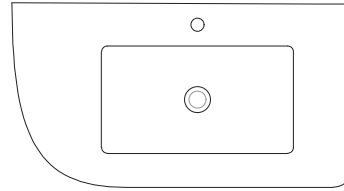

Toalleros | Porte-serviettes | Towel racks | Portasciugamani

E estándar  
Standard  
Standard  
Standard

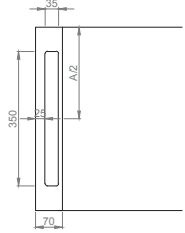

A medida  
Sur mesure  
Custom made  
Su misura

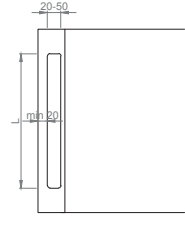

Bandeja | Plateau | Tray | Vassoio

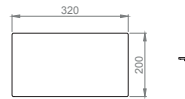

Masa interna no coloreada  
Masse interne non colorée  
Internal mass not colored  
Massa interna non colorata



Válvulas click | Bonde click | Drain click | Sifone click



Masa interna no coloreada  
Masse interne non colorée  
Internal mass not colored  
Massa interna non colorata

Copetes | Plinthes | Backsplashes | Alzatine

E estándar H 4cm  
Standard H 4cm  
Standard H 4cm  
Standard H 4cm

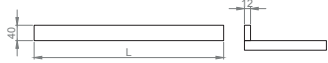

Integrado recto H 4cm  
À angle droit intégrée H 4cm  
90 degree integrated H 4cm  
Integrata ad angolo retto H 4cm



Integrado curvo H 4cm  
Concave intégrée H 4cm  
Coved integrated H 4cm  
Integrata arrotondata H 4cm

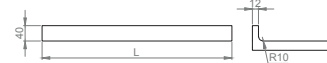

A medida H 5-30cm  
Sur mesure H 5-30cm  
Custom made H 5-30cm  
Su misura H 5-30cm

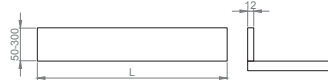

Integrado recto a media H 5-30cm  
À angle droit intégrée sur mesure H 5-30cm  
90 degree integrated Custom made H 5-30cm  
Integrata ad angolo retto Su misura H 5-30cm

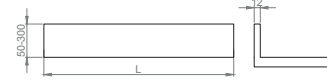

Integrado curvo a media H 5-30cm  
Concave intégrée sur mesure H 5-30cm  
Coved integrated custom made H 5-30cm  
Integrata arrotondata su misura H 5-30cm

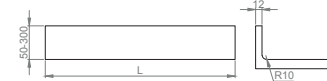

Mecanizados estándar en copete



Mecanizados a media en copete





## ARES PIZARRA

Dimensiones seno | Vasque dimensions | Washbasin dimensions | Dimensioni lavabo

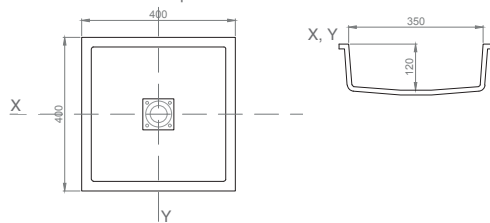

Alturas | Hauteur | Height | Altezza  
H 90cm

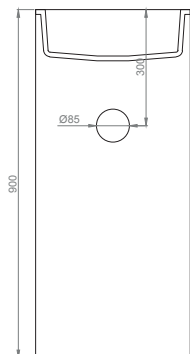

H 40cm

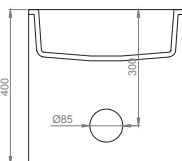

H 13cm



SM

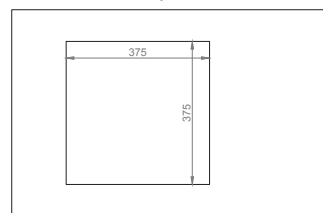
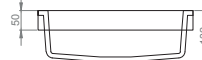

Mecanizado en encimera para SM  
Découpe sur plan de vasque pour SM  
Top hole for SM  
Taglio sul top per SM

Rejillas | Grille | Grid | Griglia



Inox AISI 316

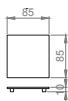

Tapa coloreada (masa interna no coloreada)  
Couvercle colorée (masse interne non colorée)  
Colored cover (internal mass not colored)  
Copri piletta colorato (massa interna non colorata)

Curvo

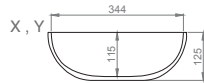
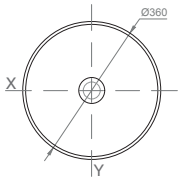

Mini

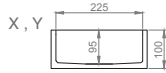
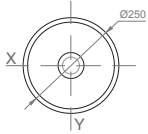

Recto

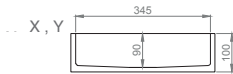
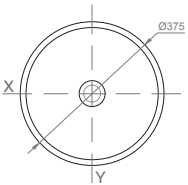

H40

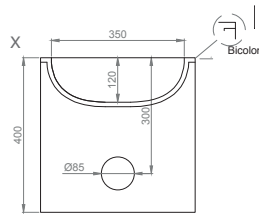
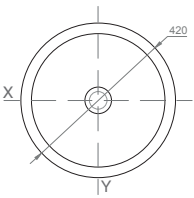

H40 con bandeja lateral  
H40 avec plateau latéral  
H40 with lateral tray  
H40 con mensola laterale

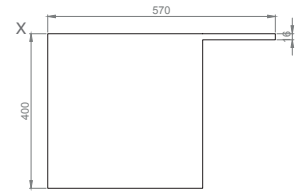
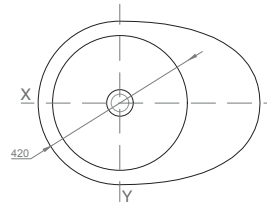

H90

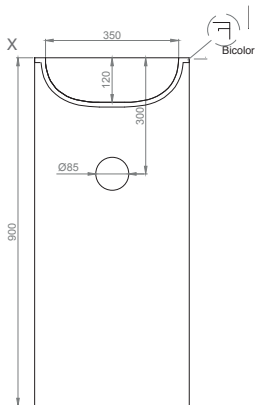
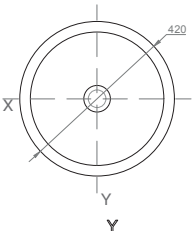

H90 con bandeja lateral  
H90 avec plateau latéral  
H90 with lateral tray  
H90 con mensola laterale

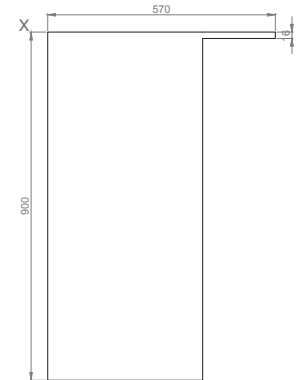
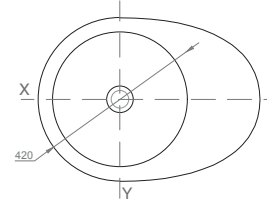

Arista redondeada en Lotto H40, H90  
Bord arrondi en Lotto H40, H90  
Rounded edge in Lotto H40, H90  
Bordo arrotondato in Lotto H40, H90

# URBAN

Dimensiones seno | Vasque dimensions | Washbasin dimensions | Dimensioni lavabo

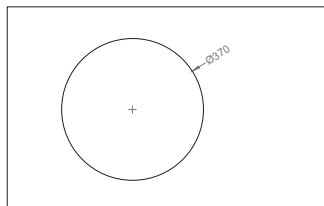
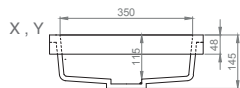
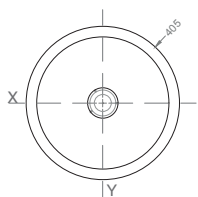

Mecanizado en encimera  
Découpe sur plan de vasque  
Top hole  
Taglio sul top

Tapa | Couvercle | Top | Copertura



Tapa coloreada (masa interna no coloreada)  
Couvercle colorée (masse interne non colorée)  
Colored cover (internal mass not colored)  
Copri piletta colorato (massa interna non colorata)

Dimensiones seno | Vasque dimensions | Washbasin dimensions | Dimensioni lavabo

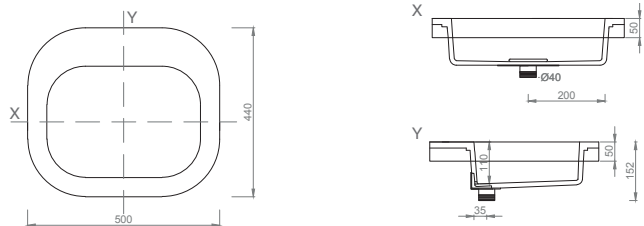

Alturas | Hauteur | Height | Altezza

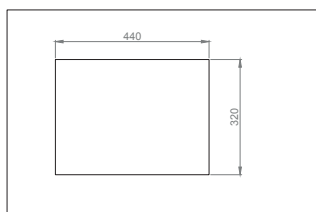
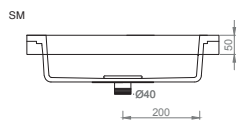
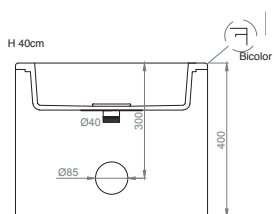
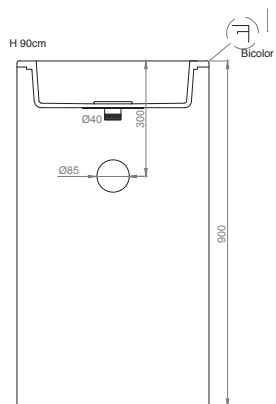

Mecanizado en encimera para SM  
 Découpe sur plan de vasque pour SM  
 Top hole for SM  
 Taglio sul top per SM

OPCIONES | OPTIONS | OPTIONS | OPZIONI

Orificio de grifo  
 Trou du robinet  
 Tap hole  
 Buco per rubinetto

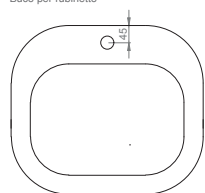

Bandeja lateral  
 Plateau latéral  
 Lateral tray  
 Vassoio laterale

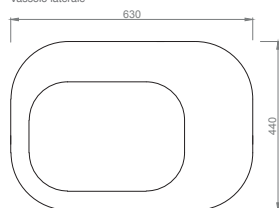

Bandeja lateral con toallero  
 Plateau latéral avec porte-serviettes  
 Lateral tray with towel racks  
 Vassoio laterale con portasciugamani

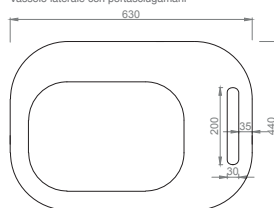



# NEO | TREVOL

## Curvo

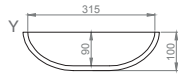
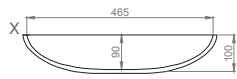
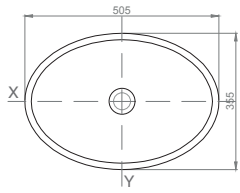

## Recto

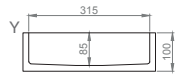
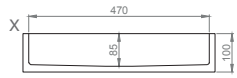
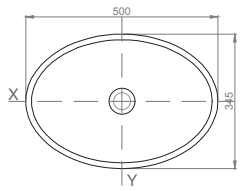

Paneles | Panneaux | Panels | Pannelli

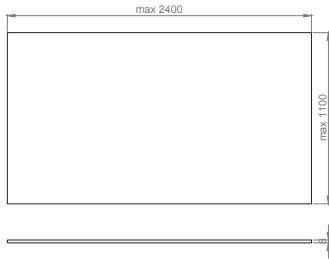

Zócalos | Socles | Skirting | Battiscopa

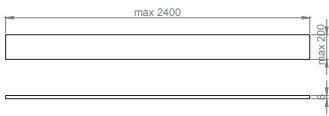

Estantes | Étagère | Shelf | Mensola

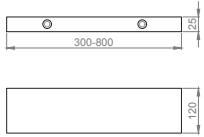

Sportes | Supports | Supports | Supporti

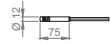

Hornacina integrada | Niche intégrée | Integrated shower niche | Mensola integrada

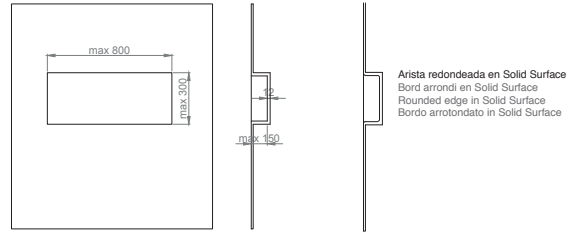

Mecanizados estándar | Trous standard | Standard holes | Fori standard



# BAÑERA HYDRA

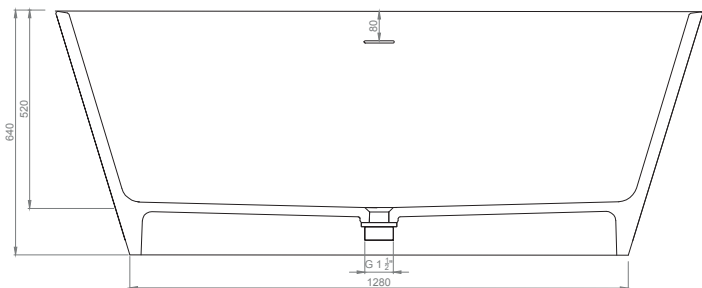
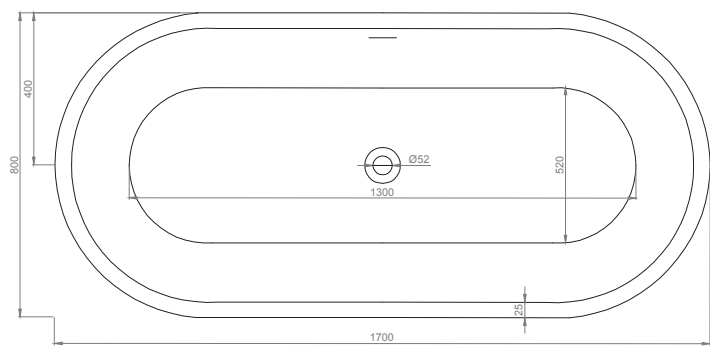

## Bandeja | Plateau | Tray | Vassoio

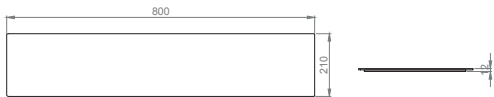



## AKRYTAN®

Akrytan® es un material compuesto por un núcleo de resina coloreada\* mezclada con cargas minerales y un acabado superficial con propiedades sanitarias de elevada resistencia. La formulación de la resina que compone Akrytan confiere a los productos mejoras en su fragilidad, carencia del fenómeno de hidrólisis y un peso un 30% menor que los productos fabricados con otras resinas del mercado.

(\* La masa interna está coloreada de forma aproximada al acabado superficial, no idéntica. Las rayas o rozaduras, sobre todo en colores oscuros, pueden provocar la aparición de polvo y marcas blancas superficiales derivadas del rayado del mineral interno.

- Antideslizante
- Antibacterias
- Coloreado en masa
- Personalizable
- No hidrolisis
- Fácil limpieza
- Alta dureza
- Reparable
- Ligero
- Baja fragilidad
- Resistencia UV

Akrytan® est un matériel composé d'un noyau de résine teintée\* mélangée avec des charges minérales et une finition superficielle avec des propriétés sanitaires de haute résistance. L'élaboration de la résine qui compose Akrytan confère aux produits des améliorations du point de vue de la fragilité, une carence du phénomène d'hydrolyse et un poids plus léger de 30 % que les produits fabriqués avec des résines du marché.

(\* La masse interne a une couleur semblable à celle de la finition superficielle mais pas identique. Les rayures ou les éraflures, surtout dans les tons obscurs, peuvent provoquer l'apparition de poussière et de marques blanches superficielles issues du rayage du minéral interne.

- Antiglisse
- Antibactérien
- Teinté dans la masse
- Personnalisable
- Sans hydrolyse
- Entretien facile
- Grande dureté
- Réparable
- Léger
- Faible fragilité
- Résistance aux UV

**Akrytan®** is a material whose core is composed of coloured resin\* mixed with mineral fillers. It has a high-strength hygienic surface. The formula for the resin used in Akrytan makes products less fragile, is devoid of hydrolysis and weighs 30% less than products manufactured with other resins on the market.

(\* The colour of the inner mass is close to the surface finish, but not identical. Scratches and scuffs, especially on darker colours, can create dust and white marks on the surface from scratching the internal mineral.

- Anti-slip
- Antibacterial
- Mass-coloured
- Customisable
- Hydrolysis-free
- Easy to clean
- High-strength
- Repairable
- Light
- Durable
- UV resistance

**Akrytan®** è un materiale composto da un'anima di resina colorata\* miscelata con cariche minerali e una finitura superficiale ad alta resistenza con proprietà sanitarie. La formulazione della resina che compone Akrytan rende i prodotti meno fragili, evita il fenomeno dell'idrolisi e consente una riduzione del peso del 30% rispetto ai prodotti realizzati con altre resine sul mercato.

(\* La massa interna è colorata in una tinta vicina ma non identica a quella della finitura superficiale. I graffi, specialmente nei colori scuri, possono causare la comparsa di polvere e macchie bianche superficiali causate dalla scalfitura del minerale interno.

- Antiscivolo
- Antibatterico
- Colorato nella massa
- Personalizzabile
- Esente da idrolisi
- Facile da pulire
- Di elevata durezza
- Riparabile
- Leggero
- Con bassa fragilità
- Resistente ai raggi UV.

## AKRYTAN®-Solid

Akrytan®-Solid es un material uniforme formado por una resina compacta de base acrílica complementada con pigmentos y cargas minerales de altas prestaciones. También llamada de forma habitual Solid Surface este material destaca por la suavidad de su tacto además de por sus propiedades mecánicas, químicas, higiénicas y de fácil reparación. Es el material ideal para utilizar en los proyectos arquitectónicos más exigentes.

- Antideslizante
- Antibacterias
- Coloreado en masa
- Personalizable
- No hidrolisis
- Fácil limpieza
- Alta dureza
- Reparable
- Ligero
- Baja fragilidad
- Resistencia UV

**Akrytan® Solid** est un matériel uniforme formé d'une résine compacte avec une base en acrylique complétée de pigments et de charges minérales de haute qualité. Ce matériel, qu'on appelle habituellement Solid Surface, se démarque grâce à sa douceur au toucher mais également à ses propriétés mécaniques, chimiques, hygiéniques et sa facilité à être réparé. Il est idéal pour les projets architecturaux les plus exigeants.

- Antiglisse
- Antibactérien
- Teinté dans la masse
- Personnalisable
- Sans hydrolyse
- Entretien facile
- Grande dureté
- Réparable
- Léger
- Faible fragilité
- Résistance aux UV

**Akrytan®-Solid** is a uniform material made up of a compact acrylic-based resin complemented with high-performance pigments and mineral fillers. Also commonly known as Solid Surface, this material stands out for its soft texture as well as its mechanical, chemical, hygienic and easy-to-repair qualities. It is the ideal material to use in the most demanding architectural projects.

- Anti-slip
- Antibacterial
- Mass-coloured
- Customisable
- Hydrolysis-free
- Easy to clean
- High-strength
- Repairable
- Light
- Durable
- UV resistance

**Akrytan®-Solid** è un materiale uniforme composto da una resina compatta a base acrilica integrata da pigmenti ad alte prestazioni e cariche minerali. Conosciuto anche come Solid Surface, questo materiale si distingue per la sua morbidezza al tatto e per le sue proprietà meccaniche, chimiche, igieniche e per la facile riparabilità. È il materiale ideale per i progetti architettonici più difficili.

- Antiscivolo
- Antibatterico
- Colorato nella massa
- Personalizzabile
- Esente da idrolisi
- Facile da pulire
- Di elevata durezza
- Riparabile
- Leggero
- Con bassa fragilità
- Resistente ai raggi UV

### NORMATIVAS | RÈGLES | REGULATIONS | NORMATIVA

Todos los productos, tanto Akrytan® como Akrytan®-Solid cumplen:

Tous les produits, aussi bien Akrytan® que Akrytan®-Solid sont conformes en termes de :

All products, both Akrytan® and Akrytan®-Solid comply with:

Tutti i prodotti, sia Akrytan® che Akrytan®-Solid, sono conformi alle norme per:

PRODUCTO	ENSAYO	NORMATIVA	RESULTADO
Plato de ducha	Resbaladicidad   Surface glissante   Slipperiness   Scivolosità	UNE ENV 12633	Clase 3
Plato de ducha	Aptitud para limpieza   Aptitude pour le nettoyage   Cleaning suitability   Idoneità alla pulizia	UNE EN 14527	Clase 1
Plato de ducha	Durabilidad   Durabilité   Durability   Durata	UNE EN 14527	Clase 1
Encimeras y lavabos	Aptitud para limpieza   Aptitude pour le nettoyage   Cleaning suitability   Idoneità alla pulizia	UNE EN 14688	Pasa
Encimeras y lavabos	Resistencia a carga   Résistance à la charge   Load resistance   Resistenza al carico	UNE EN 14688	Pasa
Encimeras y lavabos	Protección desbordamiento   Protection débordement   Overflow protection   Protezione da sversamenti	UNE EN 14688	Clase 00
Encimeras y lavabos	Durabilidad   Durabilité   Durability   Durata	UNE EN 14688	Pasa
Encimeras y lavabos	Rayado y abrasión   Rayage et abrasion   Scratching and abrasion   Graffi e abrasioni	UNE EN 14688	Pasa

## CERTIFICADOS | CERTIFICATS | CERTIFICATEES | CERTIFICAZIONI

Trabajamos con una premisa clara: ofrecer productos y servicios de la mejor calidad. Y esto nos ha llevado a contar con el aval de diferentes entidades de carácter internacional y sus respectivos sellos de calidad.

Nous travaillons avec une prémisses claire: offrir des produits et services de la plus haute qualité. Et cela nous a permis de compter avec le soutien de différentes entités et leurs labels de qualité de caractère internationaux respectifs.

We work with a clear aim: to offer the best quality products and services. And this has led us to rely on the endorsement of different international entities and their respective quality hallmarks.

Preoccupandoci della qualità offriamo ai nostri clienti, noi disponiamo di una moltitudine di certificati che garantiscono la qualità di tutti i nostri prodotti.



Cumplimos con los requisitos de seguridad en aquellos productos regulados por normativas europeas.

CE: Marquage CE, déclaration de conformité avec les normes européennes.

We comply with the safety requirements on products enforced by European regulations.

CE: Marchio che evidenzia il rispetto delle Direttive Europee.



Recogida selectiva de residuos por gestores autorizados.

Gestion des déchets par des organismes autorisés.

Selective collection of waste by authorised administrators.

La gestione dei rifiuti da parte delle agenzie autorizzate.

## ENTIDADES ASOCIADAS | ENTITÉS ASSOCIÉS | COLLABORATING ENTITIES | ENTITÀ ASSOCIATE

EMPRESA ASOCIADA



Para la mejora de los procesos de calidad de nuestros productos, trabajamos con laboratorios especializados.

Pour l'amélioration des procédés de qualité de nos produits, nous travaillons avec des laboratoires spécialisés.

For the improvement of the quality procedures of our products, we work in specialised laboratories.

Per il miglioramento delle procedure di qualità dei nostri prodotti, noi lavoriamo con i seguenti laboratori specializzati.





## Credits

---

Concepto & Dirección de arte\_\_Xarquitectos  
Diseño gráfico\_\_Xarquitectos  
Fotografía\_\_Ángel Segura Foto  
Impresión\_\_Artegraf

### Thanks to:

Neve rubinetterie  
Fima Carlo Fratini  
Buades  
Valoffice  
Vitra  
Carl Hansen  
Artek  
Stua  
Inclass  
Naxani  
Viabizzuno

### **Resigres 2010 S.L.U.**

Camí La Mar 27 | Polígono Industrial L'Horteta  
46138 Rafelbunyol (Valencia) SPAIN  
Tel (+34) 961 411 590  
Fax (+34) 961 411 014  
info@resigres.com  
www.resigres.com